

MSUNDUZI MUNICIPALITY GENERIC ENVIRONMENTAL MANAGEMENT PROGRAM

April 2017

PREPARED BY:
MSUNDUZI MUNICIPALITY
ENVIRONMENTAL MANAGEMENT UNIT



Conditions relating to this report

This report must not be altered or added to without the prior written consent of the author/s. This also refers to electronic copies of this report which are supplied for the purposes of inclusion as part of other reports / plans / programs. This report, in no way exempts the applicant from complying with relevant legislative requirements. Implementation of this report must be discussed with the Msunduzi Municipalities Environmental Management Unit.

Executive Summary

An EMPr is a detailed plan / programme of measures to prevent environmental degradation due to construction and operational phase development activities. Its purpose is to describe how negative environmental impacts will be managed, rehabilitated and monitored and how positive impacts will be maximized. On-going monitoring forms part of the EMPr and appropriate feedback procedures must be implemented and followed by all parties involved in the development activity. The EMPr specifies requirements which are to be implemented by the Applicant as per the scope of works and scope of the EMPr, in order to minimise and manage the potential negative impacts on the environment and ensure sustainable environmental management practices. It is essential that all EMPr requirements and conditions are understood and implemented and adhered to at all times and during all phases of the development (i.e. site establishment, construction, post construction, operational)

In accordance with the requirements of the National Environmental Management Act (NEMA, Act No. 107 of 1998) Environmental Impact Assessment (EIA) Regulations, 2014, and the requirements stipulated in the Msunduzi Environmental Management Bylaws, this EMPr is to be implemented by the Applicant as well as any engineer/s, employee/s, contractor, agent or sub-contractor appointed to act on behalf of the Applicant in the execution of the project, in order to ensure environmental compliance on site.

The specifications outlined in this EMPr are thus applicable to all / relevant activities undertaken by the Applicant as well as appointed contractors and all persons involved in the execution of the works including sub-contractors, the workforce, suppliers and volunteers for the duration of construction, operation and future maintenance.

<u>CONTENTS</u>	<u>PAGE</u>
Cover page	1
Conditions relating to this report	2
Executive Summary	3
Contents page	4
1. Glossary	5
2. Acronyms	6
3. Introduction & Background	8
4. Aim, Purpose & Scope Of The EMPr	8
4.1. The aim of an EMPr	
4.2. The purpose of an EMPr	
4.3. Scope Of EMPr	
5. Legislative Requirements	9
6. Environmental Compliance	11
6.1. Responsibilities for Environmental Management	
6.2. Training Of Employees	
6.3. Complaints Register And Environmental Incident Recording	
7. Environmental Non Compliance	12
8. The EMPr: Description Of Terms	13
8.1. Environmental Aspect	
8.2. Environmental Measures & Action Plans	
8.3. Responsibility	
8.4. The Applicant and / or Land Owner	
8.5. The Construction Manager / Contractor	
8.6. Msunduzi Municipalities Environmental Management Unit: Compliance Monitoring & Enforcement	
8.7. Priority	
9. EMPr Section A: Site Establishment & Preliminary Activities	15
10.EMPr Section B: Management Of Construction Activities & Workforce	33
11.EMPr Section C: Post Construction & Operational Activities	59
12.EMPr Section D: Decommissioning Phase	62

APPENDICES

Appendix 1: Environmental Code of Conduct	
Appendix 2: Complaints Register Format	
Appendix 3: Environmental Incidents Recording	
Appendix 4: Materials Safety Data Sheet	
Appendix 5: Alien Invasive Plant List	
Appendix 6: Indigenous Plant List	
Appendix 7: Alien Vegetation Removal & Control Programme	
Appendix 8: Generic Rehabilitation Plan	
Appendix 9: Storm Water Outlet and bedding Specifications	
Appendix 10: Waste Management Plan	
Appendix 11: Spill Contingency Plan	
Appendix 12: Non-Compliance with EMPr	
Appendix 13: Environmental Awareness Training	
Appendix 14: Response Protocol for Pollution Incidents	
Appendix 15: Confirmation of Acceptance of the EMPr by the Applicant / Developer / Project Manager	
Appendix 16: Penalties for Non-Compliance with EMPr	

1. GLOSSARY

Alien Invasive Species	Species that are classified as such by the Conservation Of Agricultural Resources Act (CARA, Act 43 of 1983) and included as Appendix 5 of this EMPr.
Biophysical Environment	All aspects of the natural environment including physical features such as watercourses, groundwater and soils as well as the biological features such as plants and animals.
City	Refers to the Msunduzi Municipal area, which comprises of five Area Based Management areas: Vulindlela, Edendale, Imbali, Central and Northern Areas
Contractor	Construction companies are appointed on behalf of the client to undertake the construction activities, as well as their subcontractors and suppliers.
Cumulative Impact	In relation to an activity, means the past, current and reasonably foreseeable future impact of an activity, considered together with the impact of activities associated with that activity, that in itself may not be significant, but may become significant when added to the existing and reasonably foreseeable impacts eventuating from similar or diverse activities
Development	Building, erection, construction or establishment of a facility, structure or infrastructure, including associated earthworks, site preparation and/or land clearing
Environment	The environment means the surroundings within which humans exist and that could be made up of water, air, soil, sand, plants and animals.
Environmental Aspect	An environmental aspect is any component of a contractor's construction activity that is likely to interact with and on the environment.
Environmental Control Officer (ECO)	A qualified person nominated by the appointed contractor and/or client who will ensure the day-to-day implementation of the EMP by contractors.
Environmental Impact	An impact or environmental impact is the change to the environment, whether desirable or undesirable, that will result from the effect of a construction activity. An impact may be the direct or indirect consequence of a construction activity.
Environmental Management Framework (EMF)	a framework that has been designed and adopted by the Municipality as a regulatory instrument with the content prescribed by the National Environmental Management Act, 1998 (Act 107 of 1998) Environmental Management Framework Regulations;
General Waste	Domestic waste, commercial waste, non-hazardous industrial waste and builders rubble e.g. paper, plastics, food, tins, wood, etc.
Hazardous Substance	Any substance that poses a significant risk to health and safety, property or the environment. These substances have been classified under the SABS Code 0228: 'The Identification and Classification of Dangerous Goods and Substances'.
Hazardous Waste	Any inorganic or organic element or compound that because of its toxicological, physical, chemical or persisting properties, may exercise detrimental acute or chronic impacts on human health or development. Hazardous wastes are classified in accordance with the 'Minimum Requirement for the Handling, Classification and Disposal of Hazardous Waste' published by the Department of Water Affairs and Forestry (1998).
Hazardous Waste Landfill Site	A waste disposal site that is designed, managed and permitted to allow for the disposal of hazardous waste substances. These sites are permitted by the Department of Water Affairs and Forestry.
Incident	The occurrence of a pollution event that will have a direct or indirect effect on surface water, groundwater and the associated plants and animals.
Offset	Measures taken to compensate for any residual significant, adverse impacts that cannot be avoided, minimised and / or rehabilitated or restored, in order to achieve no net loss. Offsets can take the form of positive management interventions such as restoration of degraded habitat, arrested degradation or averted risks.
Open Space Systems	A linkage of various ecological systems (i.e. marine, terrestrial and freshwater) ensuring that the interaction between plants, animals, energy, water nutrients and genetic material can occur in a dynamic and relatively undisturbed manner. It is both a means to conserve indigenous flora and fauna, and an important step in maintaining ecological balance within the city.
Open Spaces	Consists of two main types namely urban open spaces and natural open spaces.
Riparian Habitat / area	According to the National Water Act: includes the physical structure and associated vegetation of the areas associated with a watercourse which are commonly characterised

	by alluvial soils and which are inundated or flooded to an extent and with a frequency sufficient to support vegetation of species with a composition and physical structure distinct from those adjacent areas
Sensitive area	<p>Sensitive area includes the following –</p> <ul style="list-style-type: none"> (i) areas as defined as being sensitive within the adopted Msunduzi Environmental Management Framework (EMF); (ii) municipal conservation areas or conservation use zones in an adopted spatial development framework or any land use scheme; (iii) local protected areas which means a nature reserve or protected environment in terms of the National Environmental Management: Protected Areas Act 57 of 2003 or areas zoned as such in an adopted spatial development framework or any land use scheme ; (iv) local area worthy of protection which means an area that, although not statutorily protected, has the same or similar characteristics of protected areas and could in the future be considered for protection; (v) open spaces which includes areas zoned open space in an adopted spatial development framework or any land use scheme as well as any greenbelt, ravine, riparian area, bird sanctuary, and site of historic, ecological or archaeological value on both public and private land;¹
Social Environment	Persons likely to be directly or indirectly affected by the project construction activities.
Topsoil	The layer of soil covering the earth which provides a sustainable environment for the germination of seeds, allows water penetration, and is a source of micro-organisms and plant nutrients.
Waste	<p>'Waste' has the meaning assigned to it in Section 1 of the National Environmental Management: Waste Act 59 of 2008 and, in addition means any matter, solid, liquid, or gaseous, which can cause harm to humans, pollution or environmental degradation when advertently or inadvertently released, placed, stored, dumped, disposed, discharged or emitted to the atmosphere, land or water resources, whether or not such substance can be reduced, re-used, recycled and recovered -</p> <ul style="list-style-type: none"> a) that is surplus, unwanted, rejected, discarded, abandoned or disposed of; b) which the generator has no further use of for the purposes of production; c) that must be treated or disposed of; or d) that is identified as a waste by the Minister by notice in the Gazette, and includes waste generated by the mining, medical or any other sectors but— <ul style="list-style-type: none"> (i) a by-product is not considered to be waste; and or (ii) any portion of waste, once re-used, recycled and recovered, ceases to be waste
Water Resources	According to National Water Act includes a watercourse, surface water, estuary or aquifer
Watercourse	<p>"watercourse" means –</p> <ul style="list-style-type: none"> (a) a river or spring; (b) a natural channel or depression in which water flows regularly or intermittently; (c) a wetland, lake or dam into which, or from which, water flows; and (d) any collection of water which the Minister may, by notice in the Gazette, declare to be a watercourse as defined in the National Water Act, 1998 (Act No. 36 of 1998) and a reference to a watercourse includes, where relevant, its bed and banks
Wetland	according to the National Water Act means: land which is transitional between terrestrial and aquatic systems where the water table is usually at or near the surface, or land is periodically covered with shallow water, and which land in normal circumstances supports or would support vegetation typically adapted to life in saturated soils
Workforce	The entire project team including people employed by the Client or the Contractor, persons involved in activities related to the project, or persons present at or visiting the construction area, including permanent contractors and casual labour.

¹ As stated in the draft Environmental Management Bylaws

2. ACRONYMS

BAR	Basic Assessment Report
DEDTEA	Department Of Economic Development, Tourism And Environmental Affairs
DW&S	Department of Water & Sanitation
DWAF	Department of Water Affairs & Forestry: now known as Department of Water & Sanitation
ECO	Environmental Control Officer
EIA	Environmental Impact Assessment
EMF	Environmental Management Framework
EMPr	Environmental Management Program
I&AP's	Interested & Affected Parties
LAPs	Msunduzi Municipalities Local Area Plans
MCM&E	Msunduzi Compliance Monitoring & Enforcement: Msunduzi Environmental Management Unit
MSDS's	Material Safety Data Sheets
NEMA	National Environmental Management Act
SDF	Msunduzi Municipalities Spatial Development Framework
SEA	Strategic Environmental Assessment
SEMP	Strategic Environmental Management Plan

3. INTRODUCTION & BACKGROUND

The rights of all South African citizens to an environment that is not harmful to their health or well-being and to have the environment protected, for the benefit of present and future generations is enshrined in Section 24 of the Constitution of the Republic of South Africa (Act No. 108 of 1996). These rights are protected through legislative provision and other measures that aim at preventing pollution and ecological degradation, promoting conservation, securing ecologically sustainable development and using natural resources sustainably, while promoting justifiable economic and social development. In light of this, the integrity and continued environmental awareness needs to be incorporated into decision-making and project management, towards addressing the needs of both the natural environment and the parties affected by the activities proposed therein. Therefore there is a need for a mechanism by which developments are monitored and managed to be in keeping with sound economic, social and environmental principles – this is known as an Environmental Management Program (EMPr).

Msunduzi Municipality recognises that it has a responsibility to ensure that environmental degradation is prevented as far as reasonably possible, while at the same time ensuring that developmental activities promote sustainability and ecological integrity. The actions identified within this EMPr are in line with the vision of the Msunduzi Municipality, which states that **“By 2030, Pietermaritzburg will be a safe, vibrant city in which to live, learn, raise a family, work, play and do business”**. The actions within the EMPr also relate to the principals and actions within the Msunduzi SDF and LAPs, which take into account sustainability, innovation and environmental preservation.

Section 28 of the National Environmental Management Act (NEMA) places a “Duty of Care” on developers / Contractors / Engineers (all involved in the project / development) to ensure that the environment is protected and all impacts on the environment are minimised and remedied. The EMPr will specifically address the following key aspects:

- Mitigation measures to limit environmental impact during site establishment and the construction phase
- Responsibilities of stakeholders
- Site establishment and housekeeping plans for construction camps
- Materials management / storage and handling (hazardous and non-hazardous materials)
- Landscaping and rehabilitation of the site
- Follow up maintenance and alien plant removal
- Reporting of non-compliances²

4. AIM, PURPOSE & SCOPE OF THE EMPr

An EMPr can be defined as a detailed plan and programme of measures to prevent environmental degradation due to construction and operational phase development activities. Its purpose is to describe how negative environmental impacts will be managed, rehabilitated and monitored and how positive impacts will be maximized. On-going monitoring forms part of the EMPr and appropriate feedback procedures must be implemented and followed by all parties involved. The EMPr specifies requirements which are to be implemented by the Applicant as per the scope of works and scope of the EMPr, in order to minimise and manage the potential negative impacts on the environment and ensure sustainable environmental management practices. It is essential that all EMPr requirements and conditions are understood and implemented and adhered to at all times and during all phases of the development (i.e. site establishment, construction, post construction, operational)

² Non-compliances with the EMPr must be recorded (Appendix 13). Should incidents not be rectified within specified timeframes, this will result in penalties and/or fines being issued as per the Msunduzi Environmental Protection and Sustainability bylaw

4.1. The **aim of this EMPr** is to identify and minimise, as far as possible, potential impacts that proposed development may have on the surrounding and receiving environment during the following phases:

1. Pre-construction and planning
2. Construction
3. Post construction and rehabilitation
4. Operational / occupation and
5. Decommissioning

4.2. The purpose of an EMPr is to:

1. Encourage good management practices through planning and commitment to environmental issues;
2. Define how the management of the environment is reported and performance evaluated;
3. Define clear roles and responsibilities;
4. Provide rational and practical environmental guidelines to ensure the following:
 - Disturbance of the natural environment is limited
 - Pollution is prevented / minimised / mitigated
 - Indigenous flora and fauna are protected and conserved
 - Ensure that applicable laws, regulations, standards and guidelines for the protection of the environment are adhered to and complied with.
 - Adopt the best practicable means available to prevent or minimise adverse environmental impacts.
5. Develop waste management practices based on prevention, minimisation, recycling, treatment or disposal of wastes;
6. Describe all monitoring procedures required to identify impacts on the environment; and
7. Make employees and contractors aware of environmental obligations.

4.3. Scope Of EMPr

In accordance with the requirements of the National Environmental Management Act (NEMA, Act No. 107 of 1998) Environmental Impact Assessment (EIA) Regulations, 2014, and the requirements stipulated in the Msunduzi Environmental Management Bylaws, this EMPr is to be implemented by the Applicant as well as any engineer/s, employee/s, contractor, agent or sub-contractor appointed to act on behalf of the Applicant in the execution of the project, in order to ensure environmental compliance on site.

The specifications outlined in this EMPr are thus applicable to all / relevant activities undertaken by the Applicant as well as appointed contractors and all persons involved in the execution of the works including sub-contractors, the workforce, suppliers and volunteers for the duration of construction, operation and future maintenance.

5. Legislative Requirements

<p>NATIONAL ENVIRONMENTAL MANAGEMENT ACT (NEMA, 2014)</p>	<p>This requires local government to respect, protect and fulfil all the rights of its people while ensuring the delivery of basic needs especially to the previously disadvantaged communities. NEMA also states that for any sustainable development to occur there must be a balanced integration of social, economic and environmental factors. In addition, the act provides principles that commit every organ of state to prevent pollution, disturbance and any other negative impact on any component of the environment. Where prevention is not possible, the local authority must at least minimise or remedy the impact. Local government has to ensure adherence to these principles and follow the correct procedures in order to deal with environmental concerns, as laid out in this act</p>
<p>SECTION 28 (1) OF THE NEMA "DUTY OF CARE"</p>	<p>"(1) Every person who causes, has caused or may cause significant pollution or degradation of the environment must take reasonable measures to prevent such pollution or degradation from occurring, continuing or recurring, or, in so far as such harm to the environment is authorised by law or cannot reasonably be avoided or stopped, to minimise and rectify such pollution or degradation of the environment.</p>

	<p>(2)...the persons on whom subsection (1) imposes an obligation to take reasonable measures, including and owner or land, a person in control of land or premises, or a person who has a right to use the land or premises on which or in which – (a) any activity or process is or was performed or undertaken; or (b) any other situation exists, which causes or has caused or is likely to cause significant pollution or degradation of the environment. (3) The measures required in terms of subsection (1) may include measures to – (a) investigate, assess and evaluate the impact on the environment; (b) inform and educate employees about the environmental risks of their work and the manner in which their tasks must be performed in order to avoid causing significant pollution or degradation of the environment; (c) cease, modify or control any act, activity or process causing pollution or degradation; (d) contain or prevent the movement of pollutants or the cause of degradation; (e) eliminate the source of the pollution or degradation; or (f) remedy the effects of the pollution or degradation...”</p>
<p>IN TERMS OF SECTION 2 (4) OF NEMA “POLLUTER PAYS PRINCIPLE”</p>	<p>The ‘polluter pays’ principle provides that ‘the cost of remedying pollution, environmental degradation and consequent adverse health effects and of preventing, controlling or minimising further pollution, environmental damage or adverse health effects must be paid for by those responsible for harming the environment’. NEMA imposes a duty of care (Section 28 of NEMA) on every person who causes, has caused or may cause significant pollution or degradation of the environment to take reasonable measures to prevent the pollution or degradation of the environment from occurring, continuing or reoccurring. Insofar as such harm to the environment is authorised by law or cannot reasonably be avoided, NEMA requires that the pollution must be minimised and rectified</p>
<p>THE CONSTITUTION OF THE REPUBLIC OF SOUTH AFRICA, ACT 108 OF 1996 (SECTION 24)</p>	<p>Guarantees all citizens the right to a safe and healthy environment. It also provides the right for the benefit of present and future generations to an environment that is protected from pollution and degradation through reasonable legislation and other measures. It is the local government's responsibility in terms of the Constitution to ensure that the citizens in their respective areas are not deprived of these constitutional rights</p>
<p>SUSTAINABLE DEVELOPMENT</p>	<p>The principle of Sustainable Development has been established in the Constitution of the Republic of South Africa (108 of 1996) and given effect by NEMA. Section 1 (29) of NEMA states that:</p> <p>“1(29)...Sustainable development means the integration of social, economic and environmental factors into the planning, implementation and decision-making process so as to ensure that development serves present and future generations.”</p> <p>Similarly the guiding principles established in Section 2 (3) of NEMA state that: “2(3) Development must be socially, environmentally and economically sustainable. (4) (a) Sustainable development requires the consideration of all relevant factors including the following: (i) That the disturbance of ecosystems and loss of biological diversity are avoided, or</p> <p>where they cannot be altogether avoided, are minimised and remedied; (ii) that pollution and degradation of the environment are avoided, or where they cannot be altogether avoided, are minimised and remedied...(vii) that negative impacts on the environment and on peoples environmental rights be anticipated and prevented, and where they cannot be altogether prevented, are minimised and remedied.”</p> <p>Thus Sustainable Development requires that there is an integration of social, environmental and developmental concerns and that greater attention to each of these aspects of development will lead to the fulfilment of basic needs, improved living standards for all, better protected and managed ecosystems and a safer, more prosperous future (United Nations Department of Economic and Social Affairs, Division for Sustainable Development, 1992)</p>
<p>MSUNDUZI MUNICIPALITY STRATEGIC</p>	<p>Forms part of the greater Msunduzi EMF. The purpose of the SEA component is to bring together the findings of the various specialist studies, which have been undertaken in the Environmental Status Quo phase. The SEA has identified</p>

ENVIRONMENTAL ASSESSMENT (SEA)	development trends and concerns, which should be addressed through the implementation of 'Action Plans' and specific tasks which have been identified. In addition, a sustainability framework contained in the SEA provides the operational framework for implementation of the SEA and associated Action Plans. It includes Goals, Objectives, Criteria and limits of acceptable change for the Biophysical, Social Economic and Environmental Governance
MSUNDUZI MUNICIPALITY ENVIRONMENTAL MANAGEMENT FRAMEWORK (EMF) STATUS QUO REPORT	Specialist studies provide a good indication of the existing environmental conditions within the municipal area. It identifies areas of concern and constraints, which can be improved / addressed by implementing tasks identified in the action plans listed in the Strategic Environmental Management Plan (SEMP)
MSUNDUZI MUNICIPALITY STRATEGIC ENVIRONMENTAL MANAGEMENT PLAN (SEMP)	Has been designed to meet Msunduzi's responsibilities in terms of South Africa's legislation most notably the Constitution, NEMA and the Municipal Systems Act. The SEMP provides the foundation from which further work will be undertaken in order to improve and refine environmental goals and targets. This will be done by focusing on priority areas of concern; and gaps identified through the EMF / SEA and Public Consultation Processes. The SEMP and associated action plans are therefore a dynamic document that must continue to be expanded on and altered as the understanding of the environment improves
MSUNDUZI MUNICIPALITY INTEGRATED ENVIRONMENTAL MANAGEMENT POLICY	Approved by Msunduzi's Executive Committee (EXCO) on 07 May 2007 includes an environmental vision for the municipality. General policy principles and environmental management tools support the vision. The policy makes specific reference to the preparation of an EMPr where all municipal business units must incorporate environmental considerations into their plans
MSUNDUZI MUNICIPALITY BYLAWS	All municipal bylaws are to be complied with and adhered to during construction and operational activities for any / all proposed development. Specific reference is made to the Msunduzi Municipality Environmental Management bylaws –which details non-compliance with the EMPr
MSUNDUZI MUNICIPALITY WASTE MANAGEMENT BY-LAWS	Section 11 (3), states that: "Any person erecting or demolishing any building shall remove any surplus material and matter arising from such erection or demolition from the site or from any other land or public space affected by such material or matter during or after completion of erection or demolition, failing which the municipality may, by written notice, order the owner of such building to have such surplus material and matter removed within a period specified in such notice".
OCCUPATIONAL HEALTH AND SAFETY ACT (1993)	To provide for the health and safety of persons at work and for the health and safety of persons in connection with the use of plant and machinery; the protection of persons other than persons at work against hazards to health and safety arising out of or in connection with the activities of persons at work; to establish an advisor council for occupational health and safety; and to provide for matters connected therewith
NATIONAL ENVIRONMENTAL MANAGEMENT: WASTE ACT (NO. 59 OF 2008)	To protect health and the environment by providing reasonable measures for the prevention of pollution and ecological degradation and for securing ecologically sustainable development, to provide for institutional arrangements and planning matters

6. Environmental Compliance

6.1. Responsibilities for Environmental Management

The Property Owner and Contractor (and / or its agents) will be responsible for environmental management on site during all phases (pre-construction and planning, construction, post-construction and rehabilitation, and operation / occupation). Surrounding residents, tenants or landowners must be notified in advance of any potentially disturbing activities.

6.2. Training Of Employees

The Contractor (during pre-construction, construction, post-construction, rehabilitation and decommissioning) and the Property Owner (during post-construction and rehabilitation and operation) has a responsibility to ensure that all people involved in the project are aware of and are familiar with the environmental requirements for the project. The Engineer and Contractor are responsible for ensuring that the Environmental Training³ occurs or alternatively ensure that a suitably qualified person/s is assigned / employed to conduct training⁴. This EMPr must form part of the Terms of Appointment for all Contractors, Sub-contractors, and Suppliers. Signed confirmation⁵ of acceptance of the EMPr must be obtained.

Prior to the pre-construction, construction, post-construction and rehabilitation and decommissioning phases, all Contractors and Engineers must sign an acknowledgement⁶ verifying that they understand the EMPr and that they will comply with the conditions therein. All senior and supervisory staff members shall familiarise themselves with the full contents of this EMPr. They shall know and understand the specifications of the EMPr and be able to assist other staff members in matters relating to the EMPr.

During the operational phase, the Property Owner/ Project Manager / body corporate / Engineer / Developer etc. must understand and comply fully with the contents of the EMPr. All parties involved in the project / building / development must sign an acceptance of the EMPr⁷. The Msunduzi Municipality's Environmental Management Unit will be responsible for regular site visits to ensure compliance.

An Environmental Awareness Training programme for all construction workers must be arranged by the Contractor (during pre-construction, construction, post-construction and rehabilitation and decommissioning), and the Property Owner and residents (during operation). Before commencing with any work, all construction workers must be appropriately informed with the requirements specified in the EMPr and all relevant occupational health and safety issues. This training should be repeated for any new personnel that join the construction team.

An *Environmental Code of Conduct*⁸ has been developed that provides a simplified set of rules that must be adhered to by all persons involved with the project at all times. This is to be displayed at strategic points within the construction footprint in order to invoke constant environmental awareness.

6.3. Complaints Register And Environmental Incident Recording

All complaints received must be registered and recorded⁹ by the Engineer / Applicant in a Complaints Register kept at the site office. The complaint must be brought to the attention of the Project manager, Property Owner, SEO, who will ensure that these concerns are addressed and responded to accordingly. The following information must be recorded:

1. Time, date and details of the complaint
2. Response and investigation undertaken;
3. Rectification measures

³ Appendix 13

⁴ Contact details of this person/s must be submitted to the relevant authorities i.e. DEDETA, DW&S, MCM&E etc.

⁵ Appendix 15

⁶ Appendix 15

⁷ Appendix 15

⁸ An Environmental Code Of Conduct is attached as Appendix 1

⁹ A Complaints Register Template is attached as Appendix 2

All environmental incidents occurring on the site must be recorded¹⁰. The following information must be provided:

1. Time and date
2. Location, nature and extent of the incident
3. Rectification measures taken and responsible persons

7. Environmental Non Compliance

Difficulties may be encountered with carrying out mitigation measures that could result in future non-compliance. The Contractor and / or Property Owner shall put in place procedures to motivate staff members to comply with this EMP, and to deal with acts of non-compliance, and / or malicious damage to the environment. These acts of non-compliance must be recorded (see Appendix 12), rectified, dealt with and remedied as soon as possible.

Non-compliance with the approved Msunduzi EMP will result in a notice being issued in terms of the **Msunduzi the Environmental Management Bylaws**. Failure to comply with a notice issued will result in an offense and thus be subject to a penalty (Refer to **Environmental Management Bylaws: Offences and Penalties**). The Applicant / Land Owner will be held liable for acts of non-compliances.

8. The EMP: Description of Terms

8.1. Environmental Aspect

This details various aspects associated with the proposed project activities i.e. the Applicant / Construction Manager's activities that will interact with the environment.

8.2. Environmental Measures & Action Plans

This aspect indicates the actions required to either prevent and / or minimise any potential impacts on the environment that are associated with the proposed development / activity / application.

8.3. Responsibility

This indicates the party responsible for implementing the environmental measures and action plans as described in the EMP.

Formal responsibilities are necessary to ensure that key procedures are executed. Specific responsibilities of the Applicant, Construction Manager and Site Environmental Officer are detailed below.

8.4. The Applicant and / or Land Owner

The responsibilities of the Applicant and / or Land Owner include, but are not limited to the following. The Applicant and / or Land Owner must:

- Ensure that the Construction Manager is aware of all specifications, legal constraints, standards and procedures pertaining to the project specifically with regard to the environment;
- Ensure that all stipulations within the EMP are communicated and adhered to by the Construction Manager;
- Have overall responsibility for the implementation of the EMP;
- Ensure that suitable person/s are appointed to monitor the implementation of the EMP throughout the construction; and¹¹
- Order the removal of any person(s) and/or equipment in contravention of the specifications of the EMP;
- Be responsible for ensuring instructions to stop or cease work being undertaken in contravention of the EMP.

¹⁰ An Environmental Incidents Recording template is attached as Appendix 3

¹¹ This information must be conveyed to the Msunduzi Municipality and other relevant authorities

The Applicant and / or Land Owner should be fully conversant with the EMPr for the project, as well as all applicable environmental legislation.

8.5. The Construction Manager / Contractor

The responsibilities of the Construction Manager include, but are not limited to the following list. The construction manager must:

- Be fully knowledgeable of the EMPr and activities included in the EMPr
- Be aware of environmental legislation and details included in the EMPr
- Ensure that actions which will harm or may cause harm to the environment are prevented and steps to prevent pollution on the site are taken
- Implement remedial measures in the event of pollution incidents or environmental impacts
- Monitor and verify that environmental impacts are kept to a minimum
- Review and approve construction methods where necessary and
- Order the removal of any person(s) and/or equipment in contravention of the specifications of the EMPr

The above responsibilities listed for the Applicant/Construction Manager will also apply to any appointed sub-consultants/personnel/contractors.

8.6. Msunduzi Municipality's Environmental Management Unit: Compliance Monitoring and Enforcement (MCM&E)

The responsibilities of the MCM&E's include, but are not limited to the following. The MCM&E must:

- Be fully conversant with the EMPr
- Be fully conversant with all environmental legislation and regulations and ensure compliance on site
- Ensure that all the environmental specifications contained within this EMPr are adhered to on site
- Regularly liaise with the Construction Manager and / or Engineers on environmental matters; and
- Issue contravention / Non-compliance notices, should activities be occurring that are causing significant environmental degradation and in contravention of this EMPr
- Compile audit reports regarding the progress of the construction phases and report to all parties involved (Construction Manager, the Applicant) and the Msunduzi Municipality¹²¹³

8.7. Priority

The table below indicates when the actions for specific aspects must be implemented and/or monitored.

¹² This is specific to projects undertaken by the Msunduzi Municipality. Frequency of audit reports will be determined depending on the scope and timeframes of the project / development.

¹³ Monitoring will be the responsibility of the municipality in conjunction with the person appointed Chapter 7 Section 20(5) of Environmental Protection Bylaw

9. EMPr SECTION A: SITE ESTABLISHMENT & PRELIMINARY ACTIVITIES

	ACTIVITY	MONITORING	FREQUENCY
A.1. ACCESS TO SITE	1. ROUTING		
	1.1. The contractor must take into account any limitations identified and recommendations made by relevant officials when deciding on an access route to the construction site	– Engineer – Contractor – Msunduzi Compliance Monitoring And Enforcement (MCM&E)	Prior to moving onto site
	1.2. The location of all underground services and servitudes must be identified and confirmed		Prior to moving onto site
	1.3. Choice of access routes should take into account minimum disturbance to residents and neighbouring property owners.		Prior to moving onto site
	2. HAULAGE ROADS		
	2.1. All roads for construction access must be planned and approved by the Engineer and the MCM&E ahead of construction activities. They should not be created on an ad-hoc basis.	– Engineer – Contractor – MCM&E	Prior to moving onto site and during construction
	2.2. Roads must follow natural contours to reduce storm water erosion		Prior to moving onto site
	2.3. Roads must have as little cut and fill as possible		Prior to moving onto site
	2.4. Road widths and the area of clearance must be reduced to the minimum requirement		Before and during construction
	2.5. No trees / shrubs / groundcover is to be cleared or removed or vegetation stripped without prior permission of the Engineer and MCM&E		Before and during construction
	2.6. Agreed turning areas for haulage vehicles are to be formalised and used by the contractor. No turning manoeuvres other than at the designated places will be permitted		Prior to moving onto site
	2.7. Contractors must construct formal drainage on all temporary haulage roads in the form of side drains and mitre drains to prevent erosion and point source discharge of run-off – this must be done in consultation with the project Engineer		Prior to moving onto site
	2.8. Scour check walls must be constructed in side drains as follows:		Prior to moving onto site and during construction

	5%	20m					
	8%	10m					
	10%	5m					
	2.9. Scour checks can be constructed from rocks available on site or using driven wooden pegs. Smaller rocks must be placed on the invert of side drains upstream and downstream of the scour checks.					On construction of temporary roads / walkways	
2.10. Haulage roads must allow for the natural flow of water where required					On construction of haulage roads		
2.11. All stream / river crossings and temporary bridges must be built to the engineers specifications					On construction of haulage roads		
3. SURVEY POINTS							
3.1. Roads or trails that are cut to provide temporary access for survey work must be minimised					- Engineer - Contractor - MCM&E	During surveys and preliminary investigations	
3.2. Marking of survey points must be done with the approval of the engineer and the MCM&E						During surveys and preliminary investigations	
3.3. Vegetation clearing must be kept to a minimum during survey operations						During surveys and preliminary investigations	
<i>A list of contact details for all parties involved and emergency / hazard spill response and AMAFA etc. must be printed and placed at the site office, locations around the site and on notice boards so that it is easily obtainable under high pressure circumstances</i>							
A.2. SETTING UP OF CONSTRUCTION CAMP	1. LAYOUT						
	1.1. The Contractor and Applicant must inform the ECO and / or appointed suitably qualified site environmental officer and the Msunduzi Municipality prior to the commencement of any significant construction activity					- Contractor - Applicant / Land owner	Prior to and during construction
	1.2. Choice of site for the contractors camp requires the engineers permission and must take into account location of local residents and any ecologically sensitive areas that may be present on or near the site					- Engineer - Contractor - MCM&E	During surveys and preliminary investigations and prior to moving on to site
	1.3. The construction camp must not be situated on a flood plain or within 30 / 40 meters of a riparian area						During surveys and preliminary investigations
	1.4. If the contractor chooses to locate the camp site on private land, there must be a formal written consent provided by each party involved						During surveys and preliminary investigations

1.5. On site accommodation is not to be permitted without prior authorization from the contractor / land owner and the Msunduzi Municipality	- Contractor - Land owner	During site establishment
1.6. The construction camp must be comprised of the following: - Site offices - Ablution facilities - Designated first aid area - Designated refuse area which must be adequately covered - Eating area / facilities - Staff lockers and showers (where water and waterborne sewers are available) - Storage areas - Batching plant (if required) - Refuelling areas (if required) - Maintenance areas - Crushers (if required)	- Engineer - Contractor	During site establishment
1.7. Cut and fill must be avoided where possible during the setup of the construction camp	- Engineer - Contractor	During site establishment
1.8. The size of the construction camp must be minimised, especially where natural vegetation or grassland areas has to be cleared for its construction	- Engineer - Contractor	During site establishment
1.9. Adequate parking must be provided for site staff and visitors	- Engineer - Contractor	During site establishment
1.10. The contractor must attend to drainage of the camp site to avoid standing water and / or sheet erosion	- Engineer - Contractor	On-going on a weekly basis
1.11. Should informal roads be needed, this must be done in consultation with the Msunduzi Municipalities Environmental Management Unit. All access points and informal roads will need to be rehabilitated to the satisfaction of the Msunduzi Environmental Management Unit	- Contractor	During and after construction
1.12. Vegetation removed for any additional construction camp establishment must be kept to a minimum. No trees are to be removed without prior confirmation from the Msunduzi Municipality environmental management unit and the site environmental officer	- Msunduzi Municipality - Engineer - Contractor	Prior to and during construction
1.13. The Contractor / Engineer must ensure that there is adequate drainage of the construction camp to avoid standing water and / or sheet erosion. No discharge of storm water directly into a water course or riparian / open space area is permitted.	- Contractor - Engineer	During and after construction
1.14. No persons, other than a night-watchman / security guard, may stay overnight at the construction camp without prior approval from the Contractor / Msunduzi Municipality	- Contractor	During and after construction
1.15. The area selected for a Construction Camp should ensure there are no negative impacts on the surrounding environment. The location must be defined, fenced off and limited to authorized contractors only	- Contractor - MCM&E	Prior to and during construction
1.16. Adequate parking must be provided for site staff and visitors at the Construction camp	- Contractor	Prior to and during

	and access to site should be such that no traffic congestion occurs	- MCM&E	construction
2. ABLUTIONS			
2.1.	Where waterborne sewerage is not available, temporary chemical toilets must be provided by a company that has been approved by the engineer and the MCM&E. Such toilets must be available for all site staff, both at the camp site and on site as agree by the engineer. - Toilets should be no closer than 50m from any watercourse. A registered chemical waste company must be used to remove waste from chemical toilets on site (1 toilet per 20 workers)	- Engineer - Contractor - MCM&E	During site establishment
2.2.	The Engineer, Contractor and MCM&E must be consulted on the location of any chemical toilets	- Engineer - Contractor - MCM&E	During site establishment
2.3.	The construction of "long drop" toilets is strictly forbidden	- Engineer - Contractor - MCM&E	On-going
2.4.	Under no circumstances are open spaces and surround bush areas to be used as toilet facilities	- Engineer - Contractor	On-going
2.5.	Chemical toilets must be cleaned regularly i.e. this would depend on the number of staff utilizing the facilities but ideally on a weekly bases. Chemical toilets must be moved around to ensure that they adequately service the work areas at all times. Waste material is to be removed to a registered waste water treatment works, proof of this must be kept on site	Contractor / Applicant	During construction
2.6.	In cases where facilities are linked to existing sewage structures, all necessary regulatory requirements concerning construction and maintenance should be adhered to	Contractor	Prior to and during construction
2.7.	Ablution facilities should conform to any requirements stipulated by the Department of Health and the Msunduzi Municipality	Contractor	Prior to and during construction
2.8.	Where existing sewer pipes need to be emptied in order for rehabilitation work to commence, a Honey-Sucker must be used. In situations where a Honey-Sucker truck is not feasible, alternative methods should be discussed with the SEO and Msunduzi Municipality in order to find a reasonable and environmentally acceptable alternative	Contractor	Prior to and during construction
2.9.	An adequate supply of clean water, soap and disposable paper towels must be available for all staff working in close proximity to sewers and contaminated areas. Hand washing at regular intervals, especially prior to eating, should be encouraged.	Contractor	Prior to and during construction
2.10.	Upon completion of the project or decommissioning of the construction camp, the site shall be rehabilitated to the pre-use or determined purpose for the areas. All disturbed areas are to be rehabilitated with indigenous plant species and all alien plant species are to be removed (lists of these species are included as appendix 3 and 4 respectively)	Contractor	After construction
3. PROVISION FOR CAMP WASTE DISPOSAL¹⁴			
3.1.	Bins and / or skips must be provided at strategic locations for the disposal of waste within the construction camp	- Engineer - Contractor	During site establishment and

¹⁴ Appendix 10: Waste Management Plan

		- MCM&E	on-going
	3.2. Bins should have liner bags for efficient control and safe disposal of waste		On-going
	3.3. Recycling and the provisions of separate waste receptacles for different types of waste is recommended		During site establishment and on-going
	3.4. The contractor must ensure that all litter is collected from work areas daily and this must be disposed of at a registered landfill site / recycled	- Contractor	During construction
A.3. ESTABLISHING STORAGE AREAS			
	1. GENERAL SUBSTANCES AND MATERIALS		
	1.1. Choice of location for storage areas must take into account prevailing winds, distance to water bodies and general on-site topography	- Engineer - Contractor - MCM&E	During site establishment
	1.2. Storage areas must be designated, demarcated, and adequately fenced off	- Engineer - Contractor - MCM&E	During site establishment
	1.3. Storage areas must be secure so as to minimize the risk of crime. They should be safe from access by children / animals etc.	- Engineer - Contractor - MCM&E	During site establishment
	1.4. Fire prevention and control /suppression facilities must be present at all storage facilities	- Engineer - Contractor - MCM&E	During site establishment
	1.5. If electrical equipment is stored on site, along with flammable liquids, a fire break may be required around the storage area ¹⁵	- Engineer - Contractor - MCM&E	During site establishment and on-going maintenance of fire break
	1.6. Burning of firebreaks is to be done in consultation with the following Msunduzi business units: - Environmental Health Unit - Fire Department - Environmental Management Unit	- Land owner / applicant	Prior to burning of firebreak/s
	1.7. Storage areas for material and equipment shall be situated in a position as agreed in consultation with the Engineer and contractor. These areas shall be secured to prevent unintended damage or pollution to the environment	- Engineer - Contractor	Prior to construction
	2. HAZARDOUS SUBSTANCES AND MATERIALS		
	Hazardous substances / materials are those that are potentially poisonous, flammable, carcinogenic or toxic. Some examples of hazardous substances / materials are:		

¹⁵ This must be discussed with the Msunduzi Municipalities Environmental Management Unit and the Fire Department

	<ul style="list-style-type: none"> - Diesel - Petroleum - Oil - Bituminous products - Cement - Solvent based paints - Lubricants - Explosives - Drilling fluids - Pesticides - Herbicides - LPG 		
	2.1. Material Safety Data Sheet (MSDS) ¹⁶ must be readily available on site for all chemical and hazardous substances to be used on site. Where possible and available, MSDS's must additionally include information on ecological impacts and measures to minimise negative environmental impacts during accidental releases / escapes.	- Contractor	On-going
	2.2. Hazardous storage and refuelling areas must be bunded with an impermeable liner to protect groundwater quality. The contractor must submit a method statement to the Engineer for approval.	- Engineer - Contractor	During site establishment
	2.3. Fuel tanks must meet relevant specifications and be elevated so that leaks can be easily detected	- Engineer	During site establishment
	2.4. Storage areas containing hazardous substances/ materials must be clearly labelled	- Engineer - Contractor	During site establishment
	2.5. Proximity of the development to schools / residential areas / nature reserves etc. must be taken into account when the location of storage areas for hazardous substances are being decided	- Engineer - Contractor - MCM&E	During surveys and preliminary investigations
	2.6. Residents living adjacent to the construction site must be notified of the existence of hazardous material / substances in the area	- Engineer - Contractor - MCM&E	When moving onto site or as the relevant materials arrive on site
	2.7. Staff dealing with these materials / substances must be aware of their potential impacts and follow the appropriate safety measures	- Engineer - Contractor - MCM&E	During staff induction and on-going as necessary
	2.8. Contractors are required to submit method statements and plans for the storage of hazardous materials and emergency procedures	- Engineer - Contractor - MCM&E	Prior to establishment of storage areas
	2.9. Any effluent containing oil, grease, fuel or other industrial substances must be collected in a	- Engineer	During and after

¹⁶ Appendix 4

	suitable containment facility and removed from the site, either for resale or for appropriate disposal at a recognized facility	- Contractor - MCM&E	construction
	2.10. In the event of spills occurring, the Spills Contingency Plan ¹⁷ must be implemented. This should address the cleaning of spillage from hard surfaces, utilizing environmental friendly cleaning materials as well as the removal and disposal of polluted soil	Contractor	During construction
A.4. MATERIALS MANAGEMENT SOURCING	1. SOURCE OF MATERIALS		
	1.1. Contractors must prepare a source statement indicating the sources of all materials (including topsoil, sands, natural gravels, crushed stone, asphalt, clay liners etc.) and submit these to the engineer for approval prior to commencement of any construction activities. Where possible materials are to be locally sourced first	- Engineer	When contract has been awarded
	1.2. Where materials are borrowed (mined), proof must be provided of authorisation to utilise these materials from the landowner / mineral rights owner and the Department of Minerals and Energy (DMR)	- Engineer - Contractor - MCM&E	On receipt of borrowed materials
	1.3. A signed document from the supplier of natural materials should be obtained confirming that materials have been obtained in a sustainable manner and in compliance with relevant legislation - Contractors are not permitted to utilize resources such as electricity and water from surrounding community members for any construction activity or personal use provided there is a formal agreement in place to establish mutual understanding and compensation between the two parties.	- Engineer - Contractor	When ordering and on receipt of natural materials
	1.4. Sand and other construction material must be obtained from a source with the necessary permits i.e.: certificates indicating that the company providing material has a valid mining license which has been issued from the Department of Mineral Resources (DMR)	- Applicant / Land Owner - Contractor	Prior to and during construction
A.5. EDUCATION OF SITE STAFF ON GENERAL AND ENVIRONMENTAL CONDUCT	1. ENVIRONMENTAL EDUCATION AND AWARENESS		
	1.1. An environmental file must be kept on site which would include the following documentation: Msunduzi Municipality's Environmental Management Bylaws - Msunduzi Municipalities Generic EMPr - Confirmation of Acceptance of the EMPr by the Applicant / Developer ¹⁸ - Signed copy of Environmental Awareness Training ¹⁹ - Complaints Register ²⁰	- Applicant - Contractors	Prior to, during and after construction

¹⁷ Appendix 11

¹⁸ Appendix 15

¹⁹ Appendix 13

²⁰ Appendix 2

	<ul style="list-style-type: none"> - Environmental Incidents report²¹ - MSDS²² - Records of removal of chemical toilets waste - Spill contingency plan²³ - Response Protocol for Pollution Incidents²⁴ - Waybills for rubbish disposal at landfill 		
	<p>1.2. In terms of Section 2(h) and (j) of NEMA, the Contractor has the responsibility to ensure ALL personnel involved in the project are aware of, and familiar with, the EMPr, the key environmental issues and consequences of non-compliance to the EMPr. The Contractor must also ensure that all staff and personnel undergo the Environmental Awareness Training²⁵</p>	<ul style="list-style-type: none"> - Contractor - MCM&E 	<p>Prior to construction</p>
	<p>1.3. To ensure compliance with the EMPr by contractors, sub-contractors and employees, the Applicant must ensure that the EMPr forms part of the formal site induction for all contractors, sub-contractors and casual laborers, preferably in their native language. The induction training will, as a minimum, include the following:</p> <ol style="list-style-type: none"> a. The environmental impacts, actual or potential impacts resulting from work activities; b. The environmental benefits of improved personal performance; c. Their roles and responsibilities in achieving compliance with the EMPr, including emergency preparedness and response requirements; and d. The potential consequences of departure from specified operating procedures <p>Topics that must be covered include the following:</p> <ol style="list-style-type: none"> a. What is meant by environment b. Why the environment needs to be protect and conserved c. How construction activities can impact on the environment d. What can be done to mitigate against such impacts e. Awareness of emergency and spills response provisions f. Social responsibility during construction e.g. taking neighbouring property owners into account during construction <p>The Contractor must have proof of training (i.e. in the form of attendance registers for example).</p>	<ul style="list-style-type: none"> - 	
	<p>1.4. Environmental awareness training²⁶ must be done as many times as necessary for new workers on site</p>	<ul style="list-style-type: none"> - Contractor - MCM&E 	<p>Prior to construction and on-going</p>

²¹ Appendix 3

²² Appendix 4

²³ Appendix 11

²⁴ Appendix 14

²⁵ Appendix 13

²⁶ Appendix 13

	1.5. All contractors, sub-contractors and casual laborers must acknowledge their understanding of the EMPr and environmental responsibilities by signing an induction attendance record	<ul style="list-style-type: none"> - Contractor - MCM&E 	Prior to construction
	<p>1.6. It is the responsibility of the contractors to ensure that the site foreman is provided with no less than 1 hour environmental training and to ensure that the foreman has sufficient understanding to pass this information to the construction staff</p> <ol style="list-style-type: none"> a. Translators are to be used where necessary b. The Applicant should be on hand to answer questions; c. The engineer / MCM&E must provide contacts details to the contractor should there be a need to explain more difficult / technical issues and to answer questions d. The use of pictures and real-life examples must be used as these tend to be easily remembered e. Environmental awareness posters must be used if need be f. Construction workers must be made aware that excessive noise is discouraged when construction activities occur within 20m of a residential Area/ Hospital / Nature Reserve/ Animal Rescue Facility / Clinic / school etc. g. Use should be made of environmental awareness posters on site; h. The need for a 'clean site' policy must be explained to the construction workers. An Environmental Code Of Conduct²⁷ must be provided and placed as strategic locations within the site camp to ensure that workers are aware of their responsibilities 	<ul style="list-style-type: none"> - Engineer - Contractor - MCM&E 	Prior to moving onto site, during staff induction and on-going
	1.7. The hunting / injuring / trapping of animals is forbidden and all staff must be made aware of this.	<ul style="list-style-type: none"> - Contractor - Applicant - Engineer 	Prior to and during construction
	1.8. Local residents must be made aware of activities and be provided with contact details of relevant officials i.e. Contractors / Applicants should they require further information on the proposed development.	<ul style="list-style-type: none"> - Contractor - Applicant / Land Owner 	Prior to construction
	1.9. Prior to the commencement of construction, as well as during construction, appropriate signage must be erected along the roads / property boundaries to ensure that pedestrians / motorists / neighbouring households are aware of site works	<ul style="list-style-type: none"> - Contractor 	Prior to and during construction
	<p>1.10. The Contractor must appoint a specific staff member²⁸ directly involved in the site construction activities to oversee and ensure compliance with the EMPr. This person shall ensure the implementation of and adherence to the EMP in the contractor's execution of the day-to-day construction activities. This responsibility shall be specified in this person's duties, which will also include:</p> <ol style="list-style-type: none"> a. Liaison with the appointed ECO (if need be) and other relevant parties involved in the project b. The onsite implementation of the EMPr c. Monitoring inappropriate behaviour, environmental impacts including pollution and environmental incidents and 	<ul style="list-style-type: none"> - Contractor 	Prior to, during and after construction

²⁷ Appendix 1: Environmental Code Of Conduct

²⁸ A foreman / supervisor or other equivalent staff member. Contact details must be provided to Msunduzi Municipality's Environmental Management Unit

d. The implementation of corrective action		
2. WORKER CONDUCT ON SITE		
<p>2.1. A general regard for the social and ecological well-being of the site and adjacent areas is expected of the site staff. Workers need to be made aware of the following general rules:</p> <p>a. No alcohol / drugs to be present on site</p> <p>b. No firearms or other weapons allowed on site or in vehicles transporting staff to / from site (unless used by security personnel)</p> <p>c. Prevent excessive noise</p> <p>d. Prevent unsocial behaviour</p> <p>e. Bringing pets onto the site is forbidden</p> <p>f. No harvesting of firewood from the site or from the areas adjacent to it</p> <p>g. No harvesting of other vegetation such as muthi plants</p> <p>h. Construction staff shall make use of the facilities provided for them, as opposed to ad-hoc alternatives. (e.g.: fires for cooking; the use of surrounding bush as a toilet facility is forbidden)</p> <p>i. Trespassing on private / commercial properties adjoining the site is forbidden</p> <p>j. Driving under the influence of alcohol is prohibited and</p> <p>k. Other than pre-approved security staff, no workers shall be permitted to live on site unless authorisation has been granted from the applicant / land owner</p>	<ul style="list-style-type: none"> - Engineer - Contractor - MCM&E - Applicant / land owner 	During staff induction followed by on-going monitoring
<p>2.2. The Contractor must monitor the performance of construction workers to ensure that the points relayed during their induction have been properly understood and are being followed. If necessary a translator is to be called onto site to further explain aspects of environmental or social behaviour that are unclear.</p>	<ul style="list-style-type: none"> - Contractor - MCM&E 	Prior to and during construction
3. PERSONNEL SAFETY – must comply with the OHSA	-	
<p>1. Hard Hats</p> <p>The following personnel are required to wear hard hats:</p> <ul style="list-style-type: none"> - All persons within 10 m of any situation where any form of lifting or hoisting equipment is being undertaken; - Any personnel working in any other situation where possibility of head injury is present. 	<ul style="list-style-type: none"> - Engineer - Contractor - MCM&E 	Prior to and during construction
<p>2. Protective Gloves</p> <p>Protective gloves are to be worn by all persons engaging in the following:</p> <ul style="list-style-type: none"> - Handling of heavy or sharp edged materials; - Welding or gas cutting activities; - Handling of corrosive chemicals. 	<ul style="list-style-type: none"> - Engineer - Contractor - MCM&E 	Prior to and during construction
<p>3. Safety Footwear</p> <p>All persons entering the active working area must wear approved safety boots.</p>	<ul style="list-style-type: none"> - Engineer - Contractor - MCM&E 	Prior to and during construction
4. Safety Goggles	- Engineer	Prior to and during

	The following persons must wear safety goggles at all times: <ul style="list-style-type: none"> - Persons operating equipment under dusty conditions; - Persons engaged in cutting or welding activities; - Persons engaged in grinding activities; - Persons handling hazardous chemicals 	- Contractor - MCM&E	construction
	5. Facemask/ Visor protection The following persons must make use of a facemask/ visor: <ul style="list-style-type: none"> - Persons working where larger splashes of contaminated water, or other material which has been in contact with sewerage, are anticipate. 	- Engineer - Contractor - MCM&E	During construction
	6. Hearing protection The following persons must make use of hearing protection: <ul style="list-style-type: none"> - Persons operating noisy equipment such as jackhammers; - Persons operating noisy vehicles 	- Engineer - Contractor - MCM&E	During construction
A.6. EQUIPMENT, VEHICLES MAINTENANCE AND STORAGE	1. Construction activities must comply with applicable SANS noise standards as well as Msunduzi Municipalities Noise Abatement Bylaws	- Contractors	Prior to and during construction
	2. The equipment and vehicle maintenance yard must be situated within the boundaries of the construction camp only. No equipment or vehicle maintenance shall be allowed elsewhere on the site. Emergency repairs may be done only in cases where the vehicle or equipment cannot be moved from its location without causing further or more damage to the environment	- Contractor	Prior to construction
	3. A separate area must be allocated and adequately demarcated for wash bays for vehicles, machinery, tools and other equipment. This area is to be on an impermeable surface and drip trays must be on hand should there be any spills / leaks from machinery.	- Contractor - MCM&E	Prior to and during construction
	4. Plant and equipment shall be adequately maintained to prevent spillage of oil, diesel, fuel or hydraulic fluid. The Contractor shall repair or withdraw equipment or machinery from use if they consider these to be polluting and irreparable	- Contractor - MCM&E	During construction
	5. All hazardous substances shall be stored within a secured storage area, with impervious lining and bunding. Drip trays shall be used where appropriate	Contractor	Prior to and during construction
	6. Suitably covered receptacles must be available at all times and conveniently placed for the disposal of waste oils and greases. All used oils, grease or hydraulic fluids shall be placed therein and these receptacles shall be removed on a regular basis for recycling	Contractor	During construction
A.7. DUST AND AIR POLLUTION	1. Vehicles travelling along the access roads must adhere to speed limits to avoid creating excessive dust.	- Contractor - MCM&E	On-going
	2. Camp construction / haulage road construction areas that have been stripped of vegetation must be dampened periodically to avoid excessive dust.	- Contractor - MCM&E	On-going - More frequently during dry and

			windy conditions
	3. The contractor must make alternative arrangements (other than fires) for cooking and / or heating requirements. LPG gas cookers are permitted provided that all safety regulation are followed	- Contractor - Engineer	On-going
A.8. SOIL EROSION	1. The time that stripped areas are left open to exposure must be minimised wherever possible. Care must be taken to ensure that lead times are not excessive.	- Engineer - MCM&E	Throughout the during of the project
The stripping of vegetation during preliminary activities on site greatly increases the risk of erosion	2. Wind screening and storm water control must be undertaken to prevent soil loss from the site.	- Engineer - MCM&E	During site establishment
	3. Procedures that are in place to conserve topsoil during the construction phase of the project are to be applied to the site establishment phase e.g. top soil is to be conserved by means of covering stockpiles with suitable material to prevent sediment lose via wind / water.	- Engineer - MCM&E	Daily monitoring during site establishment
A.9. STORM WATER	1. To prevent storm water damage, the increase in storm water run-off resulting from construction activities must be estimated and the drainage system assessed accordingly. A drainage plan must be submitted to the engineer for approval and must be included in the location and design criteria.	- Engineer	During surveys and preliminary investigations
Storm water must be managed in a manner which does not encourage environmental degradation	2. During site establishment storm water culverts and drains are to be located and covered with metal grids to prevent blockages caused by litter or any other activities	- Engineer - Contractor	During site establishment
	3. Temporary cut of drains and berms are required to capture storm water and promote infiltration	- Contractor - MCM&E	During site establishment
A.10. WATER QUALITY	1. Storage areas that contain hazardous substances must be bunded with an approved impermeable liner	- Engineer - Contractor	During site establishment
	2. Spills in bunded areas must be cleaned, removed and disposed of safely from the bunded area as soon as after detection as possible to minimise the risk of pollution and a reduction in the bund capacity	- Engineer - MCM&E	During site establishment
	3. A designated bunded area is to be set aside for vehicle washing and maintenance. Materials caught in this bund area must be disposed of to a suitable waste / landfill site	- Engineer - MCM&E	During site establishment
	4. Provision must be made during site establishment for all polluted runoff to be treated to the engineers approval prior to being discharged into the storm water system - This would be required for the duration of the project	- Engineer - MCM&E	During site establishment and monitored weekly
A.11. NOISE	1. Construction activities must comply with applicable SANS noise standards as well as Msunduzi Municipality Noise Abatement Bylaws	- Contractor	Prior to and during construction
A.12. CONSERVATION OF	1. FAUNA AND FLORA		
	1.1. The KwaZulu-Natal Conservation Management Act No 9 of 1997, which applies to all fish,	- Contractor	Prior to, during and

THE NATURAL ENVIRONMENT	game, birds and other wildlife as well as plants and other living resources, must be complied with	- Engineer	after construction
	1.2. No vegetation is to be cleared without prior permission from the Engineer and the MCM&E	- Engineer - MCM&E	During site establishment and on-going
	1.3. Trees that are not to be removed must be marked, prior to site cleared, with danger tape. The MCM&E must be provided with time and the opportunity to mark vegetation that is to be conserved.	- Engineer - MCM&E	During site establishment
	1.4. Care must be taken to prevent the introduction of alien plant species to the site and surrounding areas.	- Engineer - MCM&E	On-going in camp site & areas affected by construction activities
	1.5. Disturbance to birds, animals and reptiles and their habitats must be avoided and/or minimised	- Engineer - MCM&E	On-going
	1.6. Under no circumstance should plants be harvested illegally for medicinal or other uses	- Engineer - MCM&E	During site establishment and on-going
	1.7. Under no circumstance are workers to hunt / trap or kill any animal	- Engineer - MCM&E	On-going
	2. VEGETATION REMOVAL		
	2.1. Removal of vegetation must be avoided until such time as construction is due to commence. Consultation with the Applicant and other relevant parties i.e. DEDTEA, Msunduzi Municipality is required prior to removal.	- Applicant - Contractor	Prior To Construction
	2.2. If required, adjacent property owners must be contacted and consulted with prior to the removal of trees	- Applicant - Contractor	Prior to and during construction
	2.3. All exposed surfaces must be re-vegetated and / or stabilized as soon as is practically possible to prevent erosion / loss of sediment	- Applicant - Contractor	During / After Construction
	2.4. No site is to be cleared of natural vegetation and left exposed for more than – a) one month during the wet season (summer months); or b) two months during the dry season (winter months).	- Applicant - Contractor	Prior to Construction
	2.5. Should 2.4 a) and/or b) above apply, the owner or applicant will be required to implement and cover the costs for the following measures: a) exposed areas must be re-vegetated by hydro- seeding or sowing an appropriate indigenous grass seed mix; b) the site where hydro-seeding or sowing has taken place must be maintained to ensure full establishment of the seed; c) exposed areas at risk of soil erosion must be protected using various erosion control measures i.e. sandbags, biomatting, geojute, erosion control blankets etc; and	- Applicant - Contractor	Prior to Construction

	d) Rehabilitate any areas already damaged due to soil erosion.		
	2.6. Any development application proposed adjacent to any gazetted protected area or conservation area will require suitable buffers and/or screening, determined by the Environmental Management Unit.	- Applicant - Contractor	Prior to Construction
	3. SENSITIVE AREAS		
	3.1. Areas which are identified by the Applicant and other relevant parties (I.e. DEDTEA, WESSA, Wildlands, Ezemvelo KZN wildlife, Msunduzi Municipality etc.) as being ecologically sensitive and which are adjacent to any construction work are to be suitably demarcated prior to and site works, to prevent damage by plant and labour. Temporary bonnox type fencing should be used and should be moved in phases as the construction progresses from one area to the next.	- Engineer - MCM&E	During surveys and preliminary investigations and On-going
	3.2. Temporary fencing must be installed prior to the commencement of construction to ensure that these sensitive areas are not negatively impacted on by construction activities	- Engineer - MCM&E	During surveys and preliminary investigations
	3.3. No go areas refer to open spaces, vacant land, riparian areas, wetlands, flood plains, or sites / areas identified by the Msunduzi Municipality Environmental Management Unit	- Contractor - Engineer - MCM&E	Prior to construction
A.13. ESTABLISHING OF WASTE MANAGEMENT PROCEDURES²⁹	1. The excavation and use of rubbish pits on site is forbidden	- Engineer - MCM&E	On-going
	2. Burning of waste in forbidden	- Engineer - MCM&E	On-going
	3. A fenced area must be allocated for waste sorting and disposal	- Engineer - MCM&E	During site establishment
	4. Individual skips for different types of waste i.e. domestic waste, builders' rubble etc. Must be provided	- Engineer - MCM&E	During site establishment
	5. WASTE CURRENTLY ON SITE: The site must be cleared of all litter/waste prior to any construction related activities. Waste must be disposed of at a registered waste disposal facility. This is to ensure that no waste is incorporated into the environment during the construction process. Recycling of waste material is encouraged.	- Engineer - MCM&E	During site establishment
A.14. SOCIAL IMPACTS Visual and noise disturbances	1. PUBLIC PARTICIPATION AND INVOLVEMENT		
	1.1. The contractor is required to inform neighbouring households / residents / I&AP's of proposed activities prior to the commencement of site works	- Engineer - Contractor	Prior to site establishment and construction activities

²⁹ Appendix 10: Waste Management Plan

	1.2. I&AP's can be identified by the following factors: <ul style="list-style-type: none"> - Live close to the site - Work close to the site - Those who will have their services / infrastructure affected by the project - Those who have a general interest in the project - The ward councillor for the area 	- Engineer - Contractor	Prior to site establishment and construction activities
2. NOISE IMPACTS			
	2.1. Construction vehicles are to be fitted with standard silencers prior to the beginning of construction	- Contractor - MCM&E	Prior to moving on to site
	2.2. Equipment that if fitted with noise reduction facilities (e.g. side flaps, silences etc.) will be used as per operating instructions and maintained properly during site operations.	- Contractor - MCM&E	Prior to moving on to site
3. VISUAL IMPACTS			
	3.1. Storage facilities, elevate tanks and other temporary structures on site should be located such that they have as little visual impact as possible on local residents	- Contractor - MCM&E	Prior to moving on to site
	3.2. In areas where the visual environment is particularly important (e.g. along commercial / tourism routes) the site is required to be screened with shade cloth or other suitable material prior to the commencement of site works	- Contractor - MCM&E	Prior to moving on to site
A.15. CULTURAL ENVIRONMENT	1. AREAS OF SPECIFIC IMPORTANCE		
	1.1. If an artifact on site is uncovered, work in the immediate vicinity must be stopped immediately and the applicant is to contact AMAFA. The following procedure must be followed: Construction must cease; <ul style="list-style-type: none"> - The finding/s must be reported to a local police station - The finding/s must be reported to AMAFA - An application to AMAFA must be made for a permit to move the find. 	- Contractor - Engineer	During site establishment and on-going
	1.2. Approval must be obtained from AMAFA should there be the need to demolish any sites of archaeological and cultural significance during the detailed design phase of the development. Demolition/construction work may only commence once AMAFA'S approval has being obtained.	- Contractor - Engineer	During site establishment and on-going
	1.3. Work may only resume once clearance is given in writing by an archaeologist.	- Contractor - Engineer	During site establishment and on-going
	1.4. Prior to the commencement of construction, all staff must to be made aware of what possible archaeological or historical objects of value may look like, and to notify the Engineer / Contractor should such an item be uncovered.	- Contractor - Engineer	During site establishment and on-going
	1.5. AMAFA should be contacted, in the case of graves being discovered	- Contractor - Engineer	During site establishment and

			on-going
	1.6. No structures older than sixty years may be demolished, altered or defaced without a permit from AMAFA	- Contractor - Engineer	During site establishment and on-going
A.16. SECURITY AND SAFETY	1. FENCING		
	1.1. The contractor must ensure that the site is adequately fenced in order to reduce the opportunity of criminal activities in the locality of the construction site	- Engineer	During site establishment
	1.2. Confined sites within residential / commercial areas must be fenced and manned to control access into the site. I.e. this is not always feasible for linear projects such as roads or pipelines, as such, with these projects; the contractor is to ensure that sensitive areas are fenced / demarcated. This must be done in consultation with the Msunduzi Municipalities Environmental Management Unit	- Engineer - MCM&E	During site establishment
	1.3. Potentially hazardous areas such as trenches are to be demarcated and clearly marked with danger tape	- Contractor - Engineer	During site establishment
	2. LIGHTING		
	2.1. Lighting on site is to be set out to provide maximum security and to ensure easier policing of the site, without creating a visual nuisance to local residents or businesses	- Contractor - Engineer	During site establishment and on-going
	2.2. Lighting of the site should be pointed downwards and away from oncoming traffic and surrounding properties to minimize the visual intrusion. All highly reflective materials on site must be screened with shade cloth or other appropriate screening material	- Contractor - Engineer	During site establishment and on-going
	3. RISKS ASSOCIATED WITH MATERIALS ON SITE		
	3.1. All procedures and equipment must be used in accordance with the Occupational Health and Safety Act (OHSA) regulations of South Africa, Act No. 85 of 1993	- Contractor - Site manager - Applicant/Land owner	Prior to and during construction
	3.2. Material stockpiles or stacks, such as pipes must be stable and well secured to prevent collapse and possible injury on site	- Contractor - Engineer	During site establishment and on-going
	3.3. Stockpiles should not be situated such that they obstruct natural water pathways, nor should stockpiles obstruct the line of site of pedestrians / drivers, especially at intersection / sharp corners	- Contractor - Engineer	During site establishment and on-going
	3.4. Flammable materials must be stored as far as possible from adjacent properties.	- Contractor - Engineer	During site establishment and on-going
	3.5. Fire fighting equipment must be present on site at all times as per OHSA	- Contractor - Engineer	During site establishment and on-going

	3.6. No materials are to be stored in unstable or high risk areas such as floodplains or along steep slopes	- Contractor - Engineer - MCM&E	During site establishment and on-going
	3.7. All I&AP's must be notified in advance of any known potential risks associated with the construction site and the activities on it. Examples are: - Stringing of power lines - Blasting / demolition works - Earthworks / earthmoving machinery on steep slopes above house / infrastructure - Risk to residents along haulage roads / access routes etc.	- Contractor - Engineer	24 hours prior to the activity occurring
A.17. COMPLIANCE	1. All persons employed by the Applicant or their contractors, shall abide by the requirements of the EMPr.	- Applicant - Contractors	Prior to and during construction
	2. The Applicant or contractor shall not direct a person to undertake any activity which would place them in contravention of the specifications contained within the EMPr	- Applicant - Contractors	Prior to and during construction
	3. Any members of the construction, operation or maintenance workforce found to be in breach of any of the specifications contained within the EMP may be ordered to cease work immediately and leave the site until the matter has been rectified. The order may be given orally or in writing. Confirmation in writing will be provided as soon as practically possible (but in no more than 7 working days.). The absence of a written order shall not be cause for an offender to remain on site. No extension of time will be granted for any delay or disadvantage to the Applicant brought about by an offender ordered to leave the site	- Contractor	During construction
	4. A fine system must be implemented for willful negligence or non-compliance resulting in environmental degradation or pollution. The fine system is indicated in Environmental Management Bylaw.	- Contractor	Prior to construction
	5. Should a contractor / worker be in breach of any of the specifications contained in the EMPr, the Applicant / Site Environmental Officer / lead contractor shall, verbally or in writing, instruct the responsible Contractor regarding corrective and/or remedial action required, specify a timeframe for implementation of these actions, and/or indicate that work shall be suspended should non-compliance continue. Contractors shall be responsible and shall bear the cost of any delays, corrective or remedial actions required as a result of non-compliance with the specifications and clauses of the EMPr	- Applicant - Contractor	During construction
	6. The Engineers and/or Applicant must consult and review the progress and discuss and resolve environmental concerns, non-compliances (including environmental incidents) and I&AP issues raised weekly.	- Engineer - Contractor - Applicant / Landowner	During construction
A.18. LEGAL IMPLICATIONS FOR	1. The overall responsibility for ensuring the implementation of the Environmental Management Program is the responsibility of the Applicant / Land owner. Agreement forums must be signed to ensure compliance with this.	- Applicant / Land owner - Contractor	Prior to, during construction and operation

IMPLEMENTATION OF EMPR	2. Responsibility for onsite implementation of environmental management as well as the associated cost implications of the EMPr rests with the Applicant, all appointed contractors, sub-contractors and suppliers. Agreement forms must be signed to ensure compliance with this.	<ul style="list-style-type: none"> - Applicant / Landowner - Contractor 	Prior to, during and after construction
A.19. GENERAL AESTHETICS	1. The Contractor shall ensure that the type and color of roofing and cladding materials of any new buildings and structures constructed as part of the project are selected to reduce reflection and blend with the natural environment.	<ul style="list-style-type: none"> - Contractor must consult with Project Engineer and Architect 	Prior to construction
	2. The Contractor shall not deface, paint, damage or mark any natural feature (e.g. Rocks, etc.) situated on or around the site for survey or any other purposes unless agreed beforehand with the Land owner and engineer.	<ul style="list-style-type: none"> - Applicant / Landowner - Contractor 	Prior to and during construction
	3. All permanent structures / buildings must comply with the South African Gazette National Building Regulations, SANS 10400 and in particular : <ul style="list-style-type: none"> - Part X : Environmental Sustainability and - Part XA : Energy Efficiency Both Part X and XA shall guide the development to a sustainable and environmentally sensitive direction	<ul style="list-style-type: none"> - Applicant / Landowner - Engineer 	Prior to construction
	4. The development must also be guided by the 'triple bottom line' ideals of internationally accredited BREEAM (Building Research Establishment's Environmental Assessment Method) certification. BREEAM is the world's most widely used environmental assessment method for buildings.	<ul style="list-style-type: none"> - Applicant / Landowner - Engineer - Architect 	Prior to construction
	5. Local guidelines must as be followed in order for buildings to be accredited with the Green Building Council Of South Africa (GBCSA)	<ul style="list-style-type: none"> - Applicant / Landowner - Engineer - Architect 	Prior to construction
A.20. ENERGY UTILISATION³⁰	1. Implementation and manufacture – Lifecycle analysis of materials used must be undertaken where applicable. It is best practise to utilise materials that have a low carbon footprint and are sourced within a 50km radius. Solar lighting and energy efficient technologies must be integrated into the development as far as possible.	<ul style="list-style-type: none"> - Applicant / Landowner - Engineer - Architect 	Prior to construction
	2. Energy CO₂ emission reductions – Many contemporary materials lifecycle analysis will illustrate a reduction in CO ₂ emission during manufacture or at least have a CO ₂ rating. It is best practise, the applicant / land owner / developer adheres to materials that have low CO ₂ emission, or if not used, the applicant / land owner / developer must motivate reason why they have not opted for this.	<ul style="list-style-type: none"> - Applicant / Landowner - Engineer - Architect 	Prior to construction
	3. Energy efficient external lighting – LED lighting is to be used wherever possible to help reduce	<ul style="list-style-type: none"> - Applicant / 	Prior to

³⁰ To be discussed in greater detail with the Msunduzi Municipalities Environmental Management Unit.

	carbon footprint. Motion sensor lighting to be introduced in areas not frequented often.	Landowner - Engineer - Architect	construction
	4. Energy efficient cold storage – All cold storage facilities within the development to adhere to international best practise when specifying cold storage in the kitchens/storage facilities.	- Applicant / Landowner - Engineer - Architect	Prior to construction
	5. Low or zero carbon technologies – New low carbon technology is to be implemented wherever possible namely, lighting, materials used, ablution facilities etc.	- Applicant / Landowner - Engineer - Architect	Prior to construction

10. EMPr SECTION B: MANAGEMENT OF CONSTRUCTION ACTIVITIES & WORKFORCE

	ACTIVITY	MONITOR	FREQUENCY
B.1. ACCESS TO SITE	1. HAULAGE ROADS		
	1.1. Contractors must ensure that all site, mitre drains, scour check walls on access and haul roads are functioning properly and are well maintained	- Engineer - Contractor	Weekly and after heavy rains
	2. MAINTENANCE OF ACCESS		
	2.1. Contractors must ensure that access roads are maintained in good condition by attending to potholes, corrugations and storm water damage as soon as these develop	- Engineer - Contractor	Weekly inspection
	2.2. Staff must clean surfaced roads adjacent to construction sites where materials have been spilt.	- Contractor - MCM&E	When necessary
	2.3. Compaction of soils by heavy vehicles must be avoided. Construction vehicles must be restricted to demarcated access, haulage routes and turning areas	- Contractor - MCM&E	On-going
	2.4. Cognisance of vehicle weight / dimensions must be taken when using access constructed out of certain materials e.g. paved surfaces / cobbled entranceways / makeshift pathways etc.	- Contractor - MCM&E	On-going
B.2. MAINTENANCE OF CONSTRUCTION CAMP	1. SURFACES		
	1.1. The contractor must monitor and manage drainage of the camp site to avoid standing water and soil erosion	- Engineer - Contractor - MCM&E	On-going
	1.2. Run-off from the camp site must not discharge directly into neighbouring properties or riparian areas, streams and drainage lines.	- Engineer - Contractor - MCM&E	On-going
	2. ABLUTIONS		
	2.1. Chemical toilets are to be maintained in a clean state and must be moved to ensure that they adequately service the workers (i.e. 1 toilet per 20 workers)	- Contractor - MCM&E	Weekly inspections
	2.2. The contractor is to ensure that open areas / riparian areas and / or the surrounding bush / areas are not being used as a toilet facility	- Contractor - MCM&E	Weekly inspections
	3. CAMP WASTE DISPOSAL³¹		
	3.1. The contractor must ensure that all litter is collected from the work and camp areas daily	- Contractor	On-going

³¹ Appendix 10: Waste Management Plan

		- MCM&E	
	3.2. Bins and / or skips must be emptied regularly and waste must be disposed of at a registered landfill site. Waybills for such disposals are to be kept by the contractor for review by the Engineer and MCM&E	- Contractor - Engineer - MCM&E	Weekly
	3.3. A registered chemical waste company is to be used to remove waste from chemical toilets. Waybills for disposal at a registered Waste Water Treatment Works must be kept on site for record purposes.	- Contractor - Engineer - MCM&E	Weekly
	4. EATING AREAS		
	4.1. Eating areas must be regularly serviced and cleaned to ensure the highest possible standard of hygiene and cleanliness	- Contractor	Daily
	4.2. All litter throughout the site must be picked up and placed into the bins provided – attempts must be made to recycle material as far as possible	- Contractor	Daily
	5. HOUSEKEEPING		
	5.1. The contractor must ensure that the camp and working areas are kept clean and tidy at all times. - Litter / waste must be collected regularly - Stockpiles must be stacked neatly and ensure that they are not infested with alien vegetation	- Contractor - Engineer - MCM&E	Daily
	1. ENVIRONMENTAL EDUCATION AND AWARENESS		
B.3. STAFF CONDUCT	3.4. Environmental training must be done as many times as necessary for new workers on site	- Contractor - MCM&E	Prior to and during construction
	3.5. It is the Contractors responsibility to ensure that all staff/ workers/ managers are provided with environmental training and to ensure that the managers/foremen have sufficient understanding to pass this information onto the construction staff: a. Translators are to be used where necessary b. The Applicant should be on hand to answer questions; c. The use of pictures and real-life examples is encouraged as these tend to be more easily remembered d. Use must be made of environmental awareness posters on site e. Construction workers must be made aware that they are not to make excessive noise (e.g. shouting / hooting) on site, near to commercial & residential areas f. The need for a “clean site” policy also needs to be explained to the construction workers	- Contractor - MCM&E	Prior to and during construction
	4. WORKER CONDUCT ON SITE		
	4.1. The rules that are explained in the Worker conduct section (Section A of this EMPr) must be adhered to at all times	- Engineer - Contractor - MCM&E	During staff induction followed by on-going monitoring

B.4. PUBLIC AND WORKER SAFETY	1. Security fencing must be erected prior to site works. Shade cloth should be used for screening purposes	- Contractor	Prior to and During Construction
	2. Dedicated pathways (temporary) for pedestrians can be developed to ensure safe passage around construction activities. These temporary path ways are to be rehabilitated and re-vegetated once construction is completed	- Applicant / Land Owner - Contractor	Prior to, during and after Construction
	3. Construction activities must be undertaken according to working hours stipulated by the Applicant and Engineer i.e. during normal working hours only (8:00-17:00). Authority must be obtained from the Municipality for work to be carried out outside of normal working hours.	- Applicant / Land Owner - Engineer	Prior to and During Construction
	4. A safety officer must be appointed who will continuously monitor safety conditions during demolition and construction activities.	- Applicant / Land Owner - Contractor	Prior to and During Construction
	5. Flag men must be appointed and provide ample warning of road traffic hazards.	- Applicant / Land Owner - Contractor	Prior to and During Construction
	6. The dangers associated with construction site entry and exit points and public access points shall be given special consideration.	- Applicant / Land Owner - Contractor	Prior to and During Construction
	7. All members of the construction workforce working on the site or near the roads shall be provided with the appropriate high visibility clothing to ensure that can be distinguished from the general public and be seen by motorists.	- Applicant / Land Owner - Contractor	During Construction
	8. All construction workers handling chemical or hazardous substances shall be trained in the use of such substances and the environmental, health and safety consequences of incidents.	- Applicant / Land Owner - Contractor	Prior to and During Construction
	9. The workforce must be provided with sufficient potable water and under no circumstances are they to use untreated water from local watercourses for drinking.	- Applicant / Land Owner - Contractor - Engineer	During Construction
	10. The workforce must be made aware of possible hazards associated with sewage spillage within the areas of site works / areas affected by site works. The workforce must be monitored for ill health associated with exposure to sewage contaminated areas.	- Applicant / Land Owner	During Construction
	11. Care shall be taken with electrical connections. All connections shall be treated as live until confirmed	- Applicant / Land Owner / Contractor	During Construction
	12. Lighting of the site should be pointed downwards and away from oncoming traffic and surrounding properties to minimize the visual intrusion.	- Applicant / Land Owner / Contractor	During Construction
B.5. EQUIPMENT,	1. All procedures and equipment must be used in accordance with the Occupational Health and Safety Act Regulations (OHSA) of South Africa, Act no. 85 of 1993	- Contractor - Engineer	Prior to and During construction

VEHICLES AND STORAGE			
	2. The equipment and vehicle maintenance yard must be situated within the boundaries of the construction camp only. No equipment or vehicle maintenance shall be allowed at any other sites. Emergency repairs may be done only in cases where the vehicle or equipment cannot be moved from its location without causing further or more damage to the environment	- Contractor	Prior to construction
	3. A separate area must be allocated and adequately demarcated for wash bays for vehicles, machinery, tools and other equipment. This area is to be on an impermeable surface and drip trays must be on hand should there be any spills / leaks from machinery.	- Contractor - MCM&E	Prior to and during construction
	4. Plant and equipment shall be adequately maintained to prevent spillage of oil, diesel, fuel or hydraulic fluid. The Contractor shall repair or withdraw equipment or machinery from use if they consider these to be polluting and irreparable	- Contractor - MCM&E	During construction
	5. All hazardous substances shall be stored within a secured storage area, with impervious lining and bunding. Drip trays shall be used where appropriate	- Contractor	Prior to and during construction
	6. Suitably covered receptacles must be available at all times and conveniently placed for the disposal of waste oils and greases. All used oils, grease or hydraulic fluids shall be placed therein and these receptacles shall be removed on a regular basis for recycling	- Contractor	During construction
	7. In the event of spills occurring, the engineer and contractor is to ensure that the Spill Contingency Plan ³² is implemented.	- Contractor	Prior to construction
	8. On completion of all operations, the construction site must be cleared of any/all contaminated soil which must be handled in accordance with the Spill Contingency Plan	- Contractor - MCM&E	During and after construction
	9. Fuel must be stored in tanks with lids, which will be kept firmly shut and under lock and key at all times, within a secondary containment facility	- Contractor	During construction
	10. No smoking shall be allowed in the vicinity of storage or dispensing areas	- Contractor	During construction
	11. Staff dealing with these materials / substances must be aware of their potential impacts and follow the appropriate safety measures.	- Contractor	Prior to and During construction
	12. Contractors must submit a method statement and plans for the storage of hazardous materials and emergency procedures	- Contractor	Prior to construction
	13. Fuel tanks must meet relevant specifications and be elevated so that leaks may be easily detected	- Contractor	Prior and During Construction
	14. Fuel storage areas must be at least 3.5 m from any buildings, boundaries or combustible / flammable material(s)	- Contractor	Prior to Construction
	15. Fuel decanting and refueling must take place within the construction camp only and not within other areas where site works are underway	- Contractor	During Construction
	16. Symbolic safety signs (in accordance with SABS 1186) must be erected at storage facilities and tank capacities shall be clearly indicated (in accordance with SABS 0232)	- Contractor	Prior to and during construction

³² Appendix 11

	17. All concrete mixing must take place on a designated, impermeable surface.	- Contractor - MCM&E	During construction
	18. In the event of spills occurring of any chemical / material, the DEDTEA, DW&S, relevant Msunduzi departments (i.e. environmental health, fire etc.) must be contacted and made aware of the concerns and issues. Correct procedures and protocols must be followed in accordance with Appendix 14. All spillages must be cleared up in compliance with the Waste Act (March 2009)	- Engineer - Contractor - MCM&E - Applicant / Landowner	During and after construction
B.6. TRAFFIC MANAGEMENT	The contractor is required to comply with the South African Roads Traffic Signs Manual (SARTSM), volume 1 and 2 chapter 13 regarding road signage for construction. Warning signs should include (but not limited to): - Pedestrian crossing - No overtaking - Heavy vehicles crossing The contractor is required to address the non-compliance within 7 working days	- Engineer - Contractor -	Prior to and during construction
B.7. DUST / AIR POLLUTION	1. Vehicles travelling to and from the construction site must adhere to speed limits so as to avoid producing excessive dust	- Engineer	On-going
	2. A speed limit of 30km/hr. must be adhered to on all dirt roads	- Engineer	On-going
	3. Access roads and other cleared surfaces must be dampened during dry / windy conditions to avoid excessive dust	- Engineer - Contractor	On-going
	4. Where dust is unavoidable in residential or commercial areas, screening will be required utilising wooden supports, shade cloth etc.	- Engineer - Contractor	On-going
	5. Vehicles and machinery are to be kept in good working order and meet manufactures specifications for safety, fuel consumption etc.	- Engineer - Contractor	On-going
	6. The contractor is to monitor all machinery and equipment, in terms of excessive emissions, and ensure that machinery and equipment is regularly serviced.	- Contractor	On-going
	7. No fires are permitted on site without prior authorisation from the relevant authorities (refer to Section A. item C. 1.6)	- Contractor	On-going
	8. Stock piles may cause dust and so must be managed in accordance with the materials management section of this EMPr (i.e. Section B item 7)	- Contractor	On-going
	9. Appropriate dust suppression measures must be used when dust generation is unavoidable (e.g. dampening).	- Contractor	During construction
	10. No burning of waste, such as plastic bags, cement bags and litter is permitted	- Applicant / Land Owner	During and after construction

	11.A Complaints Register ³³ must be provided to report any incidents including excessive dust.	- Contractor	During construction
	12.The Contractor must make alternative arrangements (other than fires) for cooking and / or heating requirements. LPG gas cookers may be used provided that all safety regulations are followed.	- Contractor	During construction
	13.Construction vehicles, and other machinery and equipment, must be fully serviced and maintained to ensure that unnecessary emissions do not occur.	- Contractor	During construction
B.8. SOIL EROSION	1. GENERAL		
	1.1. Soil erosion via contractor activities must be prevented. Should activities result in erosion, it is the Applicant / Contractors / Engineers responsibility to ensure that negative impacts are rectified	- Applicant - Engineer - Contractor	During and After construction
	1.2. Suitable erosion control measures must be implemented in areas sensitive to erosion i.e. storm water discharge points and steep embankments. These measures must include: a) The suitable use of sand bags or Hessian sheets. b) The prompt rehabilitation of exposed soil areas within indigenous vegetation to ensure that soil is protected from the elements. c) The removal of vegetation, only as it becomes necessary for work to proceed. d) Prevent the unnecessary removal of vegetation especially on slopes. e) All the necessary precautions in terms of design and construction of earthworks, cuts and fills must be taken.	- Applicant - Engineer - Contractor	Prior to, during and following construction
	1.3. Site clearing activities should only be conducted immediately prior to construction, to reduce the amount of time topsoil is exposed, and thus the potential for erosion and dust generation	- Applicant - Engineer - Contractor	During construction
	1.4. Wind screening and storm water control should be undertaken to prevent soil loss from the site	- Applicant - Engineer - Contractor	During construction
	1.5. Procedures that are in place to conserve topsoil during the construction phase of the project are to be applied to the set up phase. I.e. Top soil is to be conserved by means of covering stockpiles with suitable material to prevent sediment lose via wind / water.	- Applicant - Engineer - Contractor	During construction
	1.6. Soft Engineering options shall be implemented wherever possible e.g. geo-fabric / reno-mattresses and other strategies as indicated by other relevant parties (i.e. Local Municipality, DAEA etc.). Related storm water structures shall be in keeping with this soft Engineering solution	- Applicant - Engineer - Contractor	During construction
	1.7. Where trees have been cut, the stumps are to be treated with a registered herbicide but to remain on areas which are not to be developed, until such time of rehabilitation to prevent unnecessary soil instability and exacerbated erosion	- Applicant - Engineer - Contractor	During construction
	1.8. Areas underlain by sandy colluvial and alluvial deposits may be extremely susceptible to	- Applicant	During construction

³³ Appendix 2

	erosion. Trench lines can also become a route for continued erosive activity. Attention should be taken to ensure this does not occur or develop into an erosion feature (donga)	- Engineer - Contractor	
	1.9. Trenches should be excavated, and pipelines laid, within the recommended standards and recommendations of SABS 1200 LB (1983).	- Applicant - Engineer - Contractor	During construction
	1.10. Excavations in alluvium will require lateral support. Trenches deeper than 1.5 metres should be stored in any event, particularly if left open for significant periods. As a guide, batter slopes for excavation sidewalls should be restricted to the following: i) Fill and transported soils (Colluvial and alluvial soils) – 1:2 (vertical: horizontal) ii) Residual clay soils – 1:1 iii) Highly to moderately weathered bedrock – 4:1 iv) Slightly to moderately weathered bedrock with low discontinuity apertures – vertical	- Applicant - Engineer - Contractor	During construction
	1.11. It is recommended that excavations be carried out in the dry season, if possible, and that lateral support be used in all situations where shallow groundwater is encountered.	- Applicant - Engineer - Contractor	During construction
	1.12. The backfill within the trenches must be compacted to a similar permeability of the surrounding soils	- Applicant - Engineer - Contractor	During construction
	1.13. Where excavations result in alteration to stream banks, the banks must be battered to a slope that will support vegetation and must be compacted, top soiled and re-vegetated in accordance with an approved rehabilitation plan, as soon as activity has ceased on them	- Applicant - Engineer - Contractor	During construction
	1.14. Cut and fill embankments should be no steeper than the previous natural slopes unless otherwise permitted by the Msunduzi Environmental Management Unit. Cut and fill embankments steeper than the original ground levels are to be re-vegetated immediately on completion of trimming or protected against erosion using bioengineering stabilisation measures (i.e. gabion baskets / reno-mattresses etc.)	- Applicant - Engineer - Contractor	During and after construction
	1.15. Soil erosion via contractor activities must be prevented. Should activities result in excessive erosion, it is the Applicant / Contractors responsibility to ensure that negative impacts are rectified	- Applicant - Engineer - Contractor	During and After construction
	2. TOPSOIL STRIPPING AND STOCKPILING		
	2.1. Once an area has been cleared of vegetation, the top layer (normally 150mm) of soil should be removed and stockpiled in a designated area.	- Contractor - MCM&E	On-going
	3. EXPOSED SURFACES		
	3.1. The full length of the works must not be stripped of vegetation prior to commencing other activities. The time that stripped areas are exposed must be minimized where ever possible a. Top soiling and re-vegetation must commence immediately after the completion of an activity and at an agreed distance behind any work front b. Storm water control (Section B. E) and wind screening must be undertaken to prevent soil loss from the site	- Contractor - Engineer - MCM&E	On-going - As each phase of the development / project is completed

	<p>c. Spilling of spoil and excavated materials must not be permitted – all spoil material must be disposed of as instructed by the engineer</p> <p>d. Battering of all banks must be such that cut and fill embankments are no steeper than previous natural slopes unless stated otherwise by relevant authorities i.e. Msunduzi Municipality Business units, DEDTEA, EKZNW etc.</p> <p>e. Cut and fill embankments steeper than previous ground levels must be protected against erosion via gabion baskets, reno-mattresses, berms etc. this must be discussed with the relevant authorities as mentioned above</p> <p>f. All embankments unless stated otherwise by the engineer, must be protected by a cut off drain to prevent water from cascading down the face of the embankment and causing erosion</p>		
B.9. VEGETATION REMOVAL	1. Removal of vegetation must be avoided until such time as site works commence. Consultation with the Applicant and other relevant parties i.e. DEDTEA, Msunduzi Municipality is required prior to the removal of indigenous vegetation.	– Applicant – Contractor	Prior To Construction
	2. If required, adjacent property owners must be contacted and consulted with prior to the removal of trees	– Applicant – Contractor	Prior to and during construction
	3. All exposed surfaces must be re-vegetated and / or stabilized as soon as is practically possible to prevent erosion / loss of sediment	– Applicant – Contractor	During / After Construction
	4. Trees that are not to be cleared must be marked beforehand with danger tape. The SEO / DEDTEA / Msunduzi Municipality must be given a chance to mark vegetation that is to be conserved before site works	– Applicant – Contractor	Prior to Construction
B.10. ALIEN VEGETATION	1. Care must be taken to avoid the introduction of alien plant species to the site and surrounding areas. (Particular attention must be paid to imported material)	– Applicant – Contractor	After construction
	2. Existing and newly established weeds and alien invasive plant species must be removed from the site. Disposal methods must be discussed with the Msunduzi Municipalities Environmental Management Unit	– Applicant – Contractor – MCM&E	During construction
	3. The applicant / land owner must comply with conditions pertaining to alien plant removal which is included in the Msunduzi Municipality Environmental Management Bylaws and the Alien Plant Removal Plan (attached as appendix 4), as well as all NEMA invasive alien plant removal specifications	– Applicant – Contractor	During and after construction
	4. Where disturbance has occurred beyond the construction footprint, as a result of construction related activities, appropriate measures must be taken to ensure that disturbed areas are cleared of weeds and alien vegetation, rehabilitated (in accordance with Appendix 8, and re-vegetated) along with the site, to the satisfaction of the Msunduzi Municipalities Environmental Management Unit in conjunction with the DEDTEA	– Applicant – Contractor	During and after construction
B.11. STORM WATER	1. GENERAL PRINCIPALS		
	1.1. The contractor must not in any way modify or damage the banks or bed of streams/ rivers /	- Contractor	On-going

	wetlands / or any other open water bodies and drainage lines adjacent to or within the designated construction footprint - Where such disturbance is unavoidable, authorisations are required from the Msunduzi Municipality, DEATEA, DW&S	- Engineer - MCM&E	
	1.2. To prevent storm water damage, the increase in storm water run-off resulting from construction activities must be calculated and if necessary, the drainage system must be assessed / re-designed accordingly. A storm water management plan, based on sustainable urban drainage system (SUDS) principles, must be submitted by the Applicant to the Local Municipality	- Contractor - Engineer - MCM&E	On-going
	1.3. There is to be a periodic inspection of the sites drainage system to ensure that the flow of surface water is not obstructed.	- Contractor - Engineer - MCM&E	On-going
	1.4. All runoff and roof discharge must be channeled away from the buildings. Roof discharge from the site camp and other roofed facilities must be contained in rain water harvesting tanks.	- Contractor - Engineer - MCM&E	On-going
	1.5. During site establishment, storm water culverts and drains are to be located and covered with metal grids to prevent blockages (E.g. due to demolition / stockpiling etc.). These grids must be cleared of debris regularly by the contractor / applicant / land owner. This debris must be disposed of at a registered land fill site	- Contractor - Engineer - MCM&E	On-going
	1.6. Temporary cut off drains, swales and berms must be implemented to capture storm water and promote infiltration	- Contractor - Engineer - MCM&E	On-going
	1.7. Storm water pipelines must be discussed with Msunduzi Municipality's Environmental Management and Storm Water and Drainage Units with respect to discharge points. Erosion control techniques must be placed at discharge points (i.e. at the inlet and outlet pipes). - This must be done in consultation with Msunduzi Municipality business units	- Contractor - Engineer - MCM&E	On-going
	1.8. Earth, stone and rubble is to be properly disposed of. These materials must not be placed in storm water channels, drainage lines, rivers, floodplains or open / vacant land	- Contractor - Engineer - MCM&E	On-going
	1.9. Storm water must be disposed of without causing soil saturation, erosion, sloughing and without affecting the integrity of the site or any other areas	- Contractor - Engineer - MCM&E	On-going
	1.10. Provision shall be made for storm water management measures that will ensure effective run-off control and prevent erosion at run-off points and ponding in depressions	- Contractor - Engineer - MCM&E	On-going
	1.11. There should be a periodic monitoring of the site's drainage system to ensure that the water flow is unobstructed	- Contractor - Engineer - MCM&E	On-going
	1.12. All earthworks must be carried out in accordance with the guidelines stipulated in SABS	- Contractor	On-going

	1200.	- Engineer - MCM&E	
	1.13. To reduce the possibility of soil erosion, the resurfacing of newly cleared vegetated areas must take place as soon as possible after vegetation has been removed.	- Contractor - Engineer - MCM&E	On-going
	1.14. All surface runoff and water from downpipes to be discharged through velocity dissipaters prior to discharging into the environment. These structures must be fitted with screens to ensure that undesirable material such as litter does not enter the environment. Accompanying each discharge point should be suitable buffer structures (e.g. gabions, reno-mattresses) that will dissipate the energy of storm-flow and encourage infiltration thus reducing the likelihood of erosion.	- Contractor - Engineer - MCM&E	On-going
	1.15. Erosion control structures must be installed to all storm water outlets from internal storm water pipes (including runoff from roads and buildings).	- Contractor - Engineer - MCM&E	On-going
	1.16. Storm water must be filtered prior to entry into water bodies e.g. wetlands, to remove solid waste / litter	- Contractor - Engineer - MCM&E	On-going
	1.17. To limit the impacts of storm water runoff on sensitive areas the discharge of storm water runoff into rivers / streams / wetlands should be managed by means of multiple discharge points that are reasonably spread out across the development and adjoining the wetland habitat ³⁴ .	- Contractor - Engineer - MCM&E	On-going
	1.18. Post-development flows must not exceed pre-development flows		
	1.19. Outflow points should incorporate a best management practice approach to trap excess suspended solids and other pollutants originating from the construction site before entering the wetland / other sensitive areas. These will need to be regularly serviced and maintained to ensure adequate functioning and efficacy	- Contractor - Engineer - MCM&E	On-going
	1.20. Adequate attenuation dams / areas are required to be designed by a qualified engineer (these plans must be approved by the Msunduzi Municipality)	- Contractor - Engineer - MCM&E	On-going
	1.21. Site staff shall not be permitted to use any stream, river, other open water body or natural water source adjacent to or within the designated site for the purposes of bathing washing of clothing or for any construction or related activities. Municipal water (or another source approved by the Engineer) should instead be used for all activities such as washing of equipment or disposal of any type of waste (at designated areas), dust suppression, concrete mixing, compacting etc.	- Contractor - Engineer - MCM&E	On-going
	1.22. Potable water is to be sourced from an existing supply, and made available to all workers	- Contractor	On-going

³⁴ This must be done in consultation with the Msunduzi Municipality.

		– Engineer – MCM&E	
	1.23. A dedicated source of water for dust suppression purposes must be determined during site establishment and be approved by the contractor and Applicant / Land Owner and authority if necessary	– Contractor – Engineer – MCM&E	On-going
	1.24. Service-related pipelines, e.g. water pipes, electricity or telephone cables must be routed adjacent to the existing roads in order to minimise the impact of extensive ground works on the environment.	– Contractor – Engineer – MCM&E	On-going
	1.25. Clean water for hygiene, hand washing, drinking must always be available on site for staff	– Contractor – Engineer – MCM&E	On-going
2. STORM WATER DETENTION PONDS			
	2.1. Detention ponds must be vegetated either with suitable wetland vegetation or grasses from the re-vegetation specification ³⁵ . The detention ponds must not block the water flow, but should encourage spreading of the flow of water over a wider area to reduce velocity and encourage infiltration.	– Contractor – Engineer – MCM&E	On completion of detention pond construction
	2.2. Peak storm water discharge from the site / area must not be increased with the development of the area. Storm water must be detained on site through the use of storm water detention ponds wherever possible. A series of detention ponds may be required where flow volumes are high.	– Contractor – Engineer – MCM&E	As directed by the engineer and on-going monitoring
3. UNCHANNELED FLOW			
	3.1. During construction unchanneled flow must be controlled in order to avoid soil erosion. Where large areas of soil are left exposed, appropriate measure must be implemented to prevent erosion i.e. vegetation must be dug into the soils to reduce surface wash and capture eroded soil	– Contractor – Engineer – MCM&E	As surfaces become exposed
	3.2. Where surface run off is concentrated (e.g. along exposed roadways / tracks) flow must be reduced by contouring with for example hay bales, banded vegetation, generated during site clearance. If the areas must be used for construction vehicles, berms must be used instead. The berms must be at least 30 cm high and well compacted. The berms must channel concentrated flow into detention ponds or areas protected with hay bales for flow reduction and sediment capture.	– Contractor – Engineer – MCM&E	On-going
B.12. WATER QUALITY	1. Storage areas that contain hazardous substances must be banded with an approved impermeable liner	– Contractor – Engineer – MCM&E	On-going
	2. Spills in banded areas must be cleaned up, removed and disposed of safely from the banded area as soon after detection as possible to minimize pollution risk and reduced	– Contractor – Engineer	On-going

³⁵ This must be done in consultation with the Msunduzi Municipality, DEDTEA, Ezemvelo KZN Wildlife etc.

	bunding capacity	- MCM&E	
	3. No vehicle washing is allowed within 40 meters of a water course / system	- Contractor - Engineer - MCM&E	On-going
	4. Provision should be made for all polluted runoff to be treated to the approval of the Msunduzi Municipality before being discharged into the storm water system. (This will be required for the duration of the project.)	- Contractor - Engineer - MCM&E	On-going
	5. Washing of clothes, equipment or machinery within any watercourse is prohibited.	- Contractor - Engineer - MCM&E	On-going
	6. Mixing / decanting of all chemicals and hazardous substances must take place either on a tray or on an impermeable surface. Waste from these should then be disposed of to a suitable waste site.	- Contractor - Engineer - MCM&E	On-going
	7. Every effort should be made to ensure that any chemicals or hazardous substances do not contaminate the soil or ground water on site. Should this occur, it is the land owners responsibility to ensure that contaminated material is removed and that adequate rectification processes are implemented (this should be done in consultation with the Msunduzi Municipality)	- Contractor - Engineer - MCM&E	On-going
	8. Site staff shall not be permitted to use any stream, river, other open water body or natural water source adjacent to or within the designated site for the purposes of bathing, washing of clothing or for any construction or related activities. Municipal water (or another source approved by the relevant authority) should instead be used for all activities such as washing of equipment or disposal of any type of waste, dust suppression, concrete mixing, compacting etc.	- Contractor - Engineer - MCM&E	On-going
	9. The Contractor is to prevent the contamination of water by materials used during construction and ensure the following: - Implement measures to prevent seepage of liquid materials into ground where it could contaminate groundwater; - Ensure prompt cleaning up of accidental spillages (Section 20 of the National Water Act (36 of 1998)).	- Contractor - Engineer - MCM&E	On-going
	10. The Contractor is to prevent the contamination of hydrological features by diesel, grease, oil, etc. by ensuring that: - The machinery / equipment is maintained in a good operating condition; - Specially designated areas for vehicle maintenance are created; - Accidental spillages are cleaned up promptly and all contaminated material disposed appropriately.	- Contractor - Engineer - MCM&E	On-going
	11. Any contaminated soil or water must be removed and stored in an appropriate container until it can be disposed of at an approved disposal site. Way bills must be retained as proof of disposal.	- Contractor - Engineer - MCM&E	On-going

B.13. SEWAGE / WASTE WATER AND INFRASTRUCTURE	1. Discharge of waste from temporary chemical toilets into the environment is strictly prohibited. The Applicant / Property Owner will be liable for a fine (as stipulated in Msunduzi Municipality's Environmental Management Bylaws – Offences and Penalties)	– Applicant / Land Owner – Contractor	During construction
	2. The Applicant / Contractor must ensure that demolition or construction work does not damage sewage infrastructure such as pipelines, manholes, storm water infrastructure or pump stations. Should accidental damage occur, it is the Applicant / Contractors responsibility to ensure that such infrastructure is repaired - Removing fence lines must be seen as a last resort but if unavoidable, this must be replaced to the extent that it was removed and to the satisfaction of all relevant parties. Prior notification must be given to all parties to assess the fence before it is removed so when it is put back the condition can be verified. Also if construction stops for a planned or structured period of time (Christmas shut down period / public holidays for e.g.) then the fence must be reinstated for safety purposes.	– Applicant / Land owner – Engineer – Contractor	During and after construction
	3. Under no circumstance should runoff from the site be discharged into adjacent properties / open spaces / verges etc.	– Contractor – Applicant / Landowner	During and after construction
B.14. CONSERVATION OF THE NATURAL ENVIRONMENT	a) FAUNA AND FLORA		
	1.1. The KwaZulu-Natal Conservation Management Act No 9 of 1997, which applies to all fish, game, birds and other wildlife as well as plants and other living resources, must be complied with	– Contractor – Engineer	During construction
	1.2. Disturbance to birds, animals, reptiles invertebrates (earthworms, millipedes, mollusks etc.) and their habitats should be minimized wherever possible. Under no circumstances should any animals be harmed. - Strict controls and penalties will be enforced. Any incidences must be reported to the Compliance Department of DEDTEA, Msunduzi Municipalities Environmental Management Unit and Ezemvelo KZN Wildlife.	– Contractor – Engineer – MCM&E	On-going
	1.3. No natural vegetation is to be collected for use as firewood	– Contractor – Engineer – MCM&E	On-going
	1.4. No animals (domestic or wild) are to be disturbed unnecessarily and no animals are allowed to be shot, trapped or caught for any reason. - Should an animal be found, the Contractor is responsible for ensuring that the SPCA, Msunduzi Municipality, KZN Wildlife other relevant authority is contacted in order to ensure that the animal is safely relocated or, in the case of domestic animals, either returned to its owner or taken to the SPCA.	– Contractor – Engineer – MCM&E	On-going
	1.5. Placing snares and traps on site and in surrounding areas is forbidden. Should the staff and / or workers come across snares; these are to be removed immediately and disposed of.	– Contractor	On-going

	Contractors are to keep records of these findings		
	1.6. Listed alien invasive species and weeds must be removed and disposed of in accordance with existing legislation on a regular basis	– Contractor – Engineer – MCM&E	On-going
	1.7. No indigenous or medicinal 'muthi' plants may be collected or harvested at any stage of construction or operation, either from the property or from neighboring properties - Employees will be subject to fines (in terms of Msunduzi Municipalities Environmental protection and sustainability Bylaw chapter 10 section 25_offences and penalties), should they be caught removing or damaging flora on site or on surrounding properties.	– Contractor – Engineer – MCM&E	On-going
	1.8. The natural migration patterns of aquatic biota and the sustainable ecological functioning of river and stream systems must not be interfered with during construction.	– Contractor – Engineer – MCM&E	On-going
	1.9. Should any biodiversity issues arise, initial contact must be made with the Msunduzi Municipality Environmental Management Unit on 033 - 392 3241, thereafter Ezemvelo KZN Wildlife should be contacted on 033 – 845 1999	– Contractor – Engineer – MCM&E	On-going
	1.10. The Engineers / Applicant must consult and review implementation progress and discuss and resolve environmental concerns, non-compliance (including environmental incidents) and I&AP issues raised at monthly meetings. This must be adequately recorded and must be included in the site file	– Engineer – Applicant / Landowner	During construction
	1.11. No site is to be cleared of natural vegetation and left exposed for more than – a) One month during the wet season (summer months); or b) Two months during the dry season (winter months).	– Applicant – Contractor	Prior to Construction
	1.12. Should 1.11. a) and/or b) above apply, the owner or applicant will be required to implement and cover the costs for the following measures: a).Exposed areas must be re-vegetated by hydro- seeding or sowing an appropriate indigenous grass seed mix; b).The site where hydro-seeding or sowing has taken place must be maintained to ensure full establishment of the seed; c).Exposed areas at risk of soil erosion must be protected using various erosion control measures i.e. sandbags, biomatting, geojute, erosion control blankets etc.; and d).Rehabilitate any areas already damaged due to soil erosion.	– Applicant – Contractor	Prior to Construction
	1.13. Any development application proposed adjacent to any gazetted protected area, sensitive area or conservation area will require suitable buffers and/or screening, determined by the Environmental Management Unit.	– Applicant – Contractor	Prior to Construction
b) CONSERVATION OF NATURAL RESOURCES			
	2.1. Necessary measures must be taken to ensure that natural resources are not wasted. This includes: closing taps and valves, switching off lights during daytime, reducing usages of air-conditioners etc. and preventing spillages of consumables	– Applicant / land owner – Contractor	During construction

B.15. SENSITIVE AREAS	1. Areas which are identified by the Applicant and other relevant parties (i.e. DEDTEA, WESSA, Wildlands, DW&S, Ezemvelo KZN Wildlife, Msunduzi Municipality etc.) as being ecologically sensitive and which are adjacent to any construction work are to be suitably demarcated (prior to site works) to prevent damage by plant and labor. Temporary bonnox type fencing or shade cloth should be used and should be moved in phases as the construction progresses from one area to the next.	- Contractor - Engineer - MCM&E	During and after construction
	2. Sensitive areas are areas designated to be environmentally sensitive/ significant in the EMF and or SDF and or site visits from an expert/official in the field. These areas are to be monitored and under no circumstance should construction activities infringe on these areas.	- Applicant / Land owner - MCM&E	During and after construction
	3. Unauthorized entry, stockpiling, dumping or storage of equipment, material or waste shall be strictly prohibited in identified no go areas	- Engineers - Applicant	Prior to, during and after construction
	4. Gathering of firewood, fruit, plants or any other natural material on site or in areas adjacent to construction sites is prohibited	- Contractor	Prior to, during and after construction
	5. No workers shall access rehabilitated areas / sites via existing or newly shaped embankments. Identified or existing public access ways must be used	- Contractor	Prior to, during and after construction
B.16. EARTHWORKS INCLUDING DEMOLITION AND CONSTRUCTION	1. All environmentally sensitive areas must be demarcated and fenced off prior to the commencement of earthworks and/or demolition activities	- Contractor - Engineer - MCM&E	Prior to and during construction
	2. All earthworks must be undertaken in such a manner as to minimize the extent of any impacts caused by such activities	- Contractor	During construction
	3. Clearing of large area which will be exposed to wind and water over extended periods must be avoided. Only the immediate building footprint should be cleared to avoid erosion and siltation of storm water infrastructure and riparian areas.	4. Contractor 5. Engineer 6. MCM&E	Prior to and during construction
	7. Earthworks must be completed in accordance with the scope of works and facility designs	- Contractor	During construction
	8. Construction areas must be cordoned off and demarcated to prevent incidental public access	- Contractor	During construction
	9. Property boundaries are to be adequately demarcated and under no circumstance should construction activities extend beyond the construction / property boundary	- Contractor	During construction
	10. All neighboring properties must be notified prior to the commencement of construction / demolition as well as any disturbances that may occur i.e. electricity or water supply disruptions	- Contractor	During construction
B.17. FIRE MANAGEMENT	1. No open fires or uncontrolled fires are permitted on site. Open fires for cooking/ heating purposes are strictly prohibited	- Contractor	During construction
	2. The contractor must ensure that adequate fire-fighting equipment is present on the site at all times and in good working order, in accordance with fire safety regulations and insurance requirements.	- Contractor	During construction

	3. The workforce must be made aware of fire prevention and firefighting measures	- Contractor	During construction
	4. Any flammable material must be stored in areas where it does not present a fire hazard to surrounding vegetation and people. This includes bitumen, thinning agents, petrol, LPG containers, fuels and oils	- Contractor	During construction
B.18. FIRE BREAKS	If required, fire breaks must be prepared in consultation with Msunduzi Municipalities Environmental Health, Fire Department and Environmental Management Unit	- Applicant / Land owner - Contractor	Prior to, During and / or After Construction
B.19. MATERIALS MANAGEMENT	1. SOURCE OF MATERIALS		
	1.1. Contractors must prepare a source statement indicating the sources of all materials (including topsoil, sands, natural gravels, crushed stone, asphalt, clay liners etc.), and submit these to relevant authorities for approval prior to commencement of any work. Where possible materials are to be locally sourced.	- Contractor - Engineer - MCM&E	During construction
	1.2. Signed documents from suppliers of natural materials must be obtained confirming that they have been obtained in a sustainable manner and in compliance with relevant legislation i.e.: certificates indicating that the company providing material has a valid mining license which has been issued from the Department of Mineral Resources (DMR)	- Contractor - Engineer - MCM&E	During construction
	1.3. Where materials are borrowed (mined), proof must be provided of authorization to utilize these materials from the landowner / mineral rights owner and the Department of Minerals and Energy	- Contractor - Engineer - MCM&E	During construction
	1.4. Contractors are not permitted to utilize resources such as electricity and water from surrounding community members for any construction activity or personal use provided there is a formal agreement in place to establish mutual understanding and compensation between the two parties.	- Contractor - Engineer - MCM&E	During construction
	2. STOCK PILE MANAGEMENT		
	2.1. Stockpiles must not be situated such that they obstruct natural water pathways, nor should stockpiles obstruct the line of site of pedestrians / drivers.	- Contractor - Engineer - MCM&E	During construction
	2.2. Stockpiles should not exceed 2m in height unless otherwise permitted by the Msunduzi Municipality	- Contractor - Engineer - MCM&E	During construction
	2.3. If stockpiles are exposed to windy conditions or heavy rain, they should be covered either by vegetation or cloth, depending on the duration of the project. Stockpiles may further be protected by the construction of berms or low brick walls around their bases	- Contractor - Engineer - MCM&E	During construction
	2.4. Stockpiles should be kept clear of weeds and alien vegetation growth by regular weeding	- Contractor - Engineer - MCM&E	During construction
	2.5. Piles of topsoil and substrate must be piled separately and kept apart	- Contractor	During construction

		– Engineer – MCM&E	
2.6.	Topsoil (top 200 mm) is not to be mixed with subsoil. Each soil layer must be stored in its natural state	– Contractor – Engineer – MCM&E	During construction
2.7.	The soil profile must be restored to the natural structure with topsoil and sub-soil being replaced in sequence.	– Contractor – Engineer – MCM&E	During construction
2.8.	Soil is not to be stockpiled against tree trunks as this will encourage ant infestations.	– Contractor – Engineer – MCM&E	During construction
2.9.	Stockpiles are to be protected from wind and water erosion: a) Short-term stockpiling: (less than 3 weeks) erosion control measures will not need to be implemented; however, limitations on the area to be cleared will apply. b) Medium-term stockpiling: (4 weeks or more), stockpiles must be covered with biomatting in dry winter months or re-vegetated in wet summer months c) Long-term stockpiling: more than 1 month in the summer / wet season or 2 months in the dry winter season must be re-vegetated or hydro-seeding with an appropriate grass mix	– Contractor – Engineer – MCM&E	During construction
2.10.	Stockpiles may further be protected by the construction of berms, low brick walls or a sand bag barrier around their bases.	– Contractor – Engineer – MCM&E	During construction
2.11.	Soil must not be handled when it is wet as this will result in unnecessary compaction	– Contractor – Engineer – MCM&E	During construction
2.12.	In order to minimise the risk of spillage and loss through wind erosion, trucks transporting soil must not be overloaded when conveying soil to and from the site. Soil being transported over distances must be covered with a tarpaulin.	– Contractor – Engineer – MCM&E	During construction
3. HANDLING OF HAZARDOUS MATERIALS			
3.1.	All concrete mixing must take place on a designated impermeable surface	– Contractor – MCM&E	During construction and on-going
3.2.	No vehicles transporting concrete to the site may be washed on site	– Contractor – MCM&E	On-going
3.3.	No vehicles transporting, placing or compacting asphalt or any other bituminous product may be washed on site	– Contractor – MCM&E	On-going
3.4.	Lime and other powders must not be mixed during excessively windy conditions	– Contractor – MCM&E	On-going
3.5.	All substances required for vehicle maintenance and repair must be stored in sealed containers until they can be disposed of / removed from the site	– Contractor – MCM&E	On-going
3.6.	Hazardous substances / materials are to be transported in sealed containers / bags	– Contractor	On-going

		- MCM&E	
	3.7. Spraying of herbicides / pesticides must not take place under windy conditions and must comply with OHSA specifications and all relevant chemical handling laws / regulations	- Contractor - MCM&E	On-going
	3.8. Emergency contact numbers ³⁶ must be situated at strategic locations surrounding the site, to ensure that staff are able to access these numbers in case of emergencies	- Contractor - MCM&E	On-going
B.20. CONCRET MIXING	1. When mixing cement, runoff from mixing area must be contained and channeled to a sump	- Contractor	During construction
	2. If small volumes of concrete are to be mixed (manually), mixing is to be undertaken on a hard surface so that concrete waste and runoff can be contained.	- Contractor	During and after construction
	3. If large volumes are generated (should mixing trucks not be a viable option), the following requirements must be met: - Mixing area must be underlain by an impermeable surface that is sufficient to trap spills; - Runoff from the concrete mixing area is to be contained within a bunded area and channeled into a sump. - All concrete waste is to be collected and removed from the site and disposed of at an appropriate disposal site	- Contractor	During and after construction
B.21. POLLUTION CONTROL MEASURES	1. MSDS's for onsite chemicals, hydrocarbon materials and / or waste and hazardous substances shall be readily available. MSDS's should include information pertaining to environmental impacts and measures to minimize and mitigate against any potential environmental impacts which may result from an incident	- Contractor	During construction
	2. The Contractor must prepare an emergency procedure and a procedure for the management e.g. storage, decanting and disposal of hazardous substances	- Contractor	Prior to and during construction
	3. Rain water collected within containment facilities can be released, if not contaminated. If the contents of containment facilities are contaminated, the material must be removed and disposed of as hazardous waste	- Contractor	During construction
	4. The contractor must exercise suitable precautions with the storage, handling and transport of all materials that could adversely affect the environment. If pollution of any surface or groundwater occurs, it must immediately be reported in accordance with the incident reporting and communication procedure and appropriate mitigation measures must be employed	- Applicant - Contractor	During construction
	5. In the case of a spill of hydrocarbons, chemicals or bituminous material, the spill must be contained and the material, together with any contaminated soil collected and disposed of as hazardous waste	- Contractor	During construction
	6. Should a pollution incident occur the Engineer and Contractor must: a. Ensure the immediate implementation of reasonable measures to contain and minimize the impacts of the incident;	- Engineer - Contractor - Applicant /	During construction

³⁶ Emergency numbers can be found on the Spill Contingency Plan (Appendix 11)

	b. Notify all persons as per the procedure/protocol ³⁷ ; c. Undertake clean up procedures immediately; d. Record the incident in the Environmental Incident Register; e. Implement measures to prevent similar incidents from occurring in the future f. Should water sources become contaminated / spills occur in storm water / streams drainage lines etc., the DW&S and DEDTEA must be notified immediately ³⁸	– Landowner – MCM&E	
	7. Static tanks containing fuel, oil, grease or bituminous material shall be confined to the construction camp only	– Contractor	During construction
	8. Holding tanks containing fuel, hydrocarbon, chemicals shall be bunded and lined to contain any spillages. The containment volume must be 110% of the total volume stored in the tanks.	– Contractor	Prior to and During construction
	9. If hydrocarbons / chemicals are to be stored on site, then 50kg of hydro carbon absorbent is to be stored at the construction camp at all times.	–	

B.22. WASTE MANAGEMENT <i>A Waste Management Plan has been drawn up and is included as Appendix 10 of this document</i>	1. ON-SITE WASTE MANAGEMENT		
	1.1. The Waste Management Plan ³⁹ will be agreed to by the Applicant, Engineer and Contractor, and will include, but not be limited to, the re-use and recycling of any solid waste generated in construction activities	– Applicant – Engineer – Contractor	During and after construction
	1.2. Solid waste generated must be disposed of at a registered landfill site (site to be advised prior to construction)	– Contractor	During construction
	1.3. Existing infrastructure being demolished must be reused and / or recycled as far as possible	– Contractor	During construction
	1.4. All solid waste is to be stored in water tight, scavenger-proof and wind proof waste receptacles in a designated storage area which is fenced and access controlled	– Contractor – Applicant / Land Owner	During and after construction
	1.5. Recyclable waste must be separated, reused and recycled at approved facilities. Proof must be made available	– Contractor	During construction
	1.6. Different waste bins, for different waste streams, must be provided to ensure correct waste separation	– Contractor	During construction
	1.7. All non-recyclable solid waste must be disposed of at a permitted landfill site, and proof must be available and presented to the Engineer and Contractors at the weekly site visits	– Engineer – Contractor	During construction
	1.8. No building rubble may be used for any infilling work unless used as indicated in point 1.3. Nor shall this material be dumped in any vacant areas	– Contractor	During construction
	1.9. Littering and dumping of any waste is not permitted in any area particularly vacant undeveloped open areas	– Applicant – Contractor	During construction
1.10. No waste material is to be burned, buried or disposed of in any area that is not a licensed landfill site – unless used as indicated in point 1.3.	– Applicant – Contractor	During construction	

³⁷ Appendix 14

³⁸ Protocols as indicated in Appendix 14 must be followed

³⁹ Appendix 10: Waste Management Plan

1.11. An adequate number of general waste receptacles must be made available along the work front to collect waste from employees and to prevent littering	- Contractor	During construction
1.12. All general waste must be removed on a daily basis and disposed of in suitable waste receptacles	- Contractor	During construction
1.13. Bins must be clearly marked and lined for efficient control and safe disposal of waste	- Contractor	During construction
1.14. Hazardous waste must not be mixed or combined with general waste earmarked for recycling or disposal at a licensed landfill site	- Contractor	During construction
1.15. Waste bins should be cleaned out on a regular basis to prevent any windblown waste and/or visual or odor disturbance	- Contractor	During construction
1.16. Excavation and use of rubbish pits is forbidden	- Contractor	During and after construction
1.17. The bins located within the facility should be lined with appropriately sized plastic bags. The bins must have lids to prevent litter from becoming wind-blown. Bins should be regularly emptied to prevent overflow and the plastic lining should be immediately replaced. Waste collected from these bins on the property should be immediately transferred to designated waste areas located on the property to await collection by the relevant service provider or removed to a registered landfill site	- Contractor - Applicant / Land Owner	During and after construction
1.18. In addition to the waste facilities within the construction camp, provision must be made for waste receptacles to be placed at intervals along the work front	- Contractor - MCM&E	Daily On going
1.19. Littering on site is forbidden and the site must be cleared of litter at the end of each day	- Contractor - MCM&E	Daily On going
1.20. Recycling must be encouraged with the provision of separate receptacles for different types of waste and educating all staff on their use.	- Contractor - MCM&E	Daily On going
2. WASTE DISPOSAL		
2.1. NON-HAZARDOUS WASTE		
2.1.1. All waste must be removed from the site and either recycled or transported to a landfill site	- Contractor - MCM&E	Daily On going
2.1.2. Waybills must be provided for disposal and these must be inspected by the Engineer and Contractor	- Contractor - MCM&E	Checked at each site meeting
2.1.3. Waste from chemical toilets must be disposed of regularly by a suitably qualified specialist, to a registered waste treatment works and waybills must be provided. Care must be taken to avoid contamination of soils and / or water, pollution and nuisance to adjoining areas / sites	- Contractor - Engineer	On-going
2.2. HAZARDOUS WASTE		
2.2.1. Hazardous waste produced on site may include: a. Oil and other lubricants, diesel, paints and solvent; b. Containers that contained chemicals, oils or greases; and c. Equipment, steel, other material (rags), soils and water contaminated by hazardous substances (oil, fuel, grease or chemicals)	- Contractor - Engineer	On-going

	2.2.2. A lined and permeable sump must be created for concrete waste materials. This is to be de-sludged regularly and the cement waste is to be removed to an approved disposal site.	- Contractor - Engineer	On-going
	2.2.3. Hazardous waste disposal must be undertaken by an approved waste contractor, waybills for this must be provided to the Contractor and Engineer	- Contractor - Engineer	On-going
	2.2.4. Mixing/ decanting of all chemicals and hazardous substances shall take place either on a tray or container with an impermeable surface.	- Contractor - Engineer	On-going
	2.2.5. Hazardous waste is to be disposed at a Permitted Hazardous Waste Landfill Site. The contractor must provide proof of disposal.	- Contractor - Engineer	On-going
	2.2.6. Hazardous waste bins must be clearly marked and stored in a contained area and have a drip tray and cover (either stored under a roof or the container shall be covered with a lid)	- Contractor - Engineer	On-going
	2.2.7. if the waste is to be transported to a central point where it can be collected in bulk by the waste disposal company it should however be noted that: a. Transport of hazardous materials must be done in accordance with legislative control; and b. Relevant SABS Codes of Practice must be adhered to	- Contractor - Engineer	On-going
B.23. SOCIAL IMPACTS	1. DISRUPTION OF INFRASTRUCTURE AND SERVICES		
	1.1. Contractor's activities and movement of staff to be restricted to designated construction areas.	- Contractor - Engineer	On-going
	1.2. Should staff / construction workers be approached by neighbouring property owners / I&AP's, they are to refer them to the site office or assist them in locating the Engineer or Contractor.	- Contractor - Engineer	On-going
	1.3. The conduct of the staff when dealing with the public and other stakeholders must be in a manner which is polite and helpful.	- Contractor - Engineer	On-going
	1.4. Disruption of access for local residents must be minimised and must have the Engineers approval.	- Contractor - Engineer	On-going
	1.5. The contractor is to inform neighbours in writing of disruptive activities at least 24 hours in advance. This can take place by providing leaflets placed in post boxes providing the details of the disturbance along with the contract information of the contractor and / or engineer	- Contractor - Engineer	On-going
	1.6. Eskom must be consulted if electricity poles need to be moved or where stockpiles are likely to occur within Eskom servitudes	- Applicant /Land Owner - Contractor	During Construction
	2. VISUAL IMPACTS		
	2.1. Lighting on the construction site must be pointed downwards and away from oncoming traffic and nearby house. Efforts must be made to ensure that solar lights are used	- Contractor - Engineer	On-going
2.2. The site must be kept clean at all times to minimise the visual impact of site works	- Contractor - Engineer	On-going	

2.3.	Appropriate screening must be used and this must be moved and re-erected as the work front progresses	- Contractor - Engineer	On-going
3. NOISE			
3.1.	In order to minimize noise and traffic impacts associated with construction, working hours must be limited to between 07:00 and 17:00 on weekdays. No construction may take place on weekends or public holidays unless authorization is granted from the Msunduzi Municipality and DEDTEA. Construction activities must be undertaken during working hours i.e. during daylight hours only.	- Contractor - Engineer	On-going
3.2.	Construction vehicles and equipment generating excessive noise must be fitted with appropriate noise abatement measures	- Contractor - Engineer	On-going
3.3.	Construction workers must be provided with the appropriate personal protective equipment i.e. ear plugs	- Contractor - Engineer	On-going
3.4.	A complaints register must be provided to record any complaints regarding excessive noise. All complaints received must be investigated by the Contractor and a response given to the complainant within 7 days	- Contractor - Engineer	On-going
3.5.	Notice of particularly noisy activities must be given to residents / businesses adjacent to the construction site. Examples of these include: - noise generated by jackhammers - drilling - dewatering pumps - blasting	- Contractor - Engineer	On-going
3.6.	Jackhammers and their associated compressors generate continuous noise that could impact on nearby residents. Acoustic treatment of the jackhammers must include silencers.	- Contractor - Engineer	On-going
3.7.	The location of areas for delivery of equipment and materials must take into account the noise generated by vehicles as well as noise generated by off-loading equipment.	- Contractor - Engineer	On-going
3.8.	The Engineer and Contractor are responsible for on-going communication with those affected by the project i.e. neighboring property owners / residents	- Contractor - Engineer	On-going
3.9.	A Complaints Register ⁴⁰ must be kept on site at all times. This must be in a carbon copy format, with numbered pages. Any missing pages must be accounted for by the contractor. This register must be discussed during monthly site meetings	- Contractor - Engineer	Monthly
3.10	I&AP's must be made aware of the existence of the complaints register and the methods of communication available to them	- Contractor - Engineer	On-going
3.11.	All queries and complaints must be addressed by: - Documenting details of communication - Submitting these for inclusion In the complaints register - Alerting the engineers and contractors to the issues / concerns raised	- Contractor - Engineer	On-going

⁴⁰ Appendix 2

	- Taking corrective action as per the engineer / contractors instruction		
	3.12. Only staff designated by the developer / engineer are to communicate with I&AP's in order to: - Explain construction processes - Answer questions regarding construction activities and site work being conducted	- Contractor - Engineer	On-going
B.24. CULTURAL ENVIRONMENT	Specific reference is made to item A.15: Cultural Environment 1. Possible items of historical or archaeological value include (but are not limited to) old stone foundations, tools, clayware, jewelry, remains/graves, fossils etc. should items of this nature be uncovered AMAFA are to be contacted immediately and all further construction / site works are to be stopped until authorized by AMAFA	- Contractor - Engineer	As and when required
B. 25. MAINTENANCE WORK			
B.25.1. ENVIRONMENTAL MANAGEMENT BYLAWS AND THE MSUNDUZI SDF	1. Under no circumstance should any construction activity take place within 40 meters of a water course without prior confirmation and input from Msunduzi Municipality's Environmental Management Unit, the DEDTEA and the DW&S.	- Applicant - Land Owner / Contractor	Prior To Construction
	2. Buffer zones and/or sensitive areas must be rehabilitated. Alien vegetation must be removed and indigenous vegetation (comprising plants, shrubs and trees) must be planted, to create a multi-layered vegetative community. This must be done in consultation with Msunduzi Municipality's Parks & Recreation Unit and The Environmental Management Unit.	- Applicant - Land Owner / Contractor	During and after construction
B.25.2. REMOVAL OF LITTER / SILT / DEBRIS ALONG AND / OR WITHIN RIVERS/ STREAMS / BRIDGES / WATER COURSES/ WETLANDS	1. Comment and approval should be obtained from Msunduzi Municipality's Environmental Management Unit prior to the commencement of site works.	- Applicant / Land Owner - Contractor	Prior to construction / site activities
	2. No machinery is permitted within 40 meters of a water course, for the purposes of excavation / construction / removal of debris. As far as possible all work is to be done manually. Should the use of heavy vehicles be required, the Msunduzi Municipalities Environmental Management Unit must be consulted.	- Applicant / Land Owner - Contractor	Prior to construction / site activities
	3. Under no circumstances should the shape / flow or course of the river / stream / wetland be altered in any way. Should this occur, the applicant / land owner will be liable for prosecution and rehabilitation processes.	- Applicant / Land Owner - Contractor	Prior to construction / site activities
B.25.3. EROSION CONTROL ON	1. Energy dissipaters and / or gabions are required at stormwater outlet and inlet pipes to ensure that water flow is slowed down, erosion is decreased and banks / steep areas are protected from collapsing ⁴¹ .	- Applicant / Land Owner - Contractor	Prior To Construction

⁴¹ Refer to Appendix 9

BANKS / STEEP AREAS	<p>2. Appropriate erosion control methods must be implemented in areas sensitive to erosion. These measures could include:</p> <ul style="list-style-type: none"> - The suitable use of sand bags or Hessian sheets. - The prompt rehabilitation of exposed soil areas within indigenous vegetation⁴² to ensure that soil is protected from the elements. - The removal of vegetation, only as it becomes necessary for work to proceed. - Avoid the unnecessary removal of vegetation especially on steep slopes. - All necessary precautions in terms of design and construction of earthworks, cuts and fills must be taken. 	<ul style="list-style-type: none"> - Applicant / Land Owner - Contractor 	During and after construction
B.25.4. STORM WATER MANAGEMENT	<p>1. Accompanying each discharge point should be suitable buffer structures (e.g. gabions, reno-mattresses, energy dissipaters) that will dissipate the energy of storm-flow and encourage infiltration⁴³.</p>	<ul style="list-style-type: none"> - Applicant / Land Owner - Contractor 	Prior to, during and after Construction
	<p>2. To limit the impacts of storm water runoff on sensitive areas the discharge of storm water runoff into rivers / streams / wetlands should be managed by means of multiple discharge points that are reasonably spread out across the development area.</p>	<ul style="list-style-type: none"> - Applicant / Land Owner - Contractor 	Prior to, during and after Construction
	<p>3. All surface runoff and water from downpipes to be discharged with velocity dissipaters prior to discharging into the environment. These structures must be fitted with screens to ensure that undesirable material such as litter does not enter the environment.</p>	<ul style="list-style-type: none"> - Applicant / Land Owner - Contractor 	Prior to, during and after Construction
B.25.5. CONSTRUCTION OF GABIONS / RENO-MATTRESSES / SLOPE STABILISATION TECHNIQUES⁴⁴	<p>1. In cases where construction work does not trigger any NEMA listed activities, please ensure that the Msunduzi Environmental Management Unit is contacted to advise on Duty of Care principals in terms of NEMA. All municipal bylaws, policies, plans must be complied followed and adhered to.</p>	<ul style="list-style-type: none"> - Applicant / Land Owner - Contractor 	Prior to Construction
B.25.6. BUILDINGS /	<p>1. The following must be implemented in accordance with approved municipal policies / strategies and plans:</p>	<ul style="list-style-type: none"> - Applicant / Land Owner 	Prior to construction

⁴² Refer to Appendix 6

⁴³ Refer to Appendix 9 if the development does not already have an approved Storm Water Outlet design.

⁴⁴ Should this involve any of the activities listed below, NEMA would be triggered which would require the need for environmental authorisation from DEDTEA:

The infilling or depositing of any material of **more than 5 cubic metres** into, or the dredging, excavation, removal or moving of soil, sand, shells, shell grit, pebbles or rock of more than 5 cubic metres from-

(i) a watercourse;

(ii) the seashore; or

(iii) the littoral active zone, an estuary or a distance of 100 metres inland of the high-water mark of the sea or an estuary, whichever distance is the greater but excluding where such infilling, depositing, dredging, excavation, removal or moving-

(a) will occur behind a development setback;

(b) is for maintenance purposes undertaken in accordance with a maintenance management plan; or

(c) Falls within the ambit of activity 21 in this Notice, in which case that activity applies.

INFRASTRUCTURE	<ul style="list-style-type: none"> - Installation of rainwater collection / harvesting tanks - The use of solar geysers and solar lighting - Low flush toilets and low flow taps and showers - Recycling initiatives - indigenous landscaping 	- Contractor	
	2. Green building strategies and standards must be implemented in accordance with SANS regulations and the Msunduzi Municipalities Environmental Management Bylaws	<ul style="list-style-type: none"> - Applicant / Land Owner - Contractor 	Prior to and during construction

11. EMPR SECTION C: POST CONSTRUCTION & OPERATIONAL ACTIVITIES

	ACTIVITY	MONITOR	FREQUENCY
C.1. CONSTRUCTION CAMP	1. All structures comprising the construction camp must be removed from the site	<ul style="list-style-type: none"> - Engineer - Contractor - Applicant / land owner 	Project completion
	2. The area where the construction camp was located is to be checked for spills of substances such as oil, chemicals, paints etc. Should there be spills, these must be cleaned up immediately in accordance with the Spill Contingency Plan ⁴⁵	<ul style="list-style-type: none"> - Engineer - Contractor - Applicant / land owner 	Project completion
	3. All hardened surfaces within the construction camp are to be ripped and if necessary removed ⁴⁶ in consultation with the MCM&E and contractor/s. - All imported materials must be removed and the area must be topsoil and re-grassed and re-vegetated i.e. refer to Appendix 8: Rehabilitation Plan	<ul style="list-style-type: none"> - MCM&E - Contractor 	Project completion
	4. The contractor must arrange for the cancellation of all temporary services	<ul style="list-style-type: none"> - MCM&E - Contractor 	Project completion
C.2. VEGETATION	1. All areas that have been disturbed by construction activities (this includes the construction camp/site area) must be cleared of all alien vegetation irrespective of whether it was on site prior to construction activities or not. This must be done in accordance with Appendix 5, 6 and 7	<ul style="list-style-type: none"> - Engineer - Contractor - MCM&E 	Project completion
	2. Open areas are to be re-vegetated as per the Rehabilitation Plan i.e. Appendix 8	<ul style="list-style-type: none"> - Engineer - Contractor - MCM&E 	Project completion
	3. All vegetation that has been cleared during construction is to be removed from site or used as mulch (except for alien vegetation)	<ul style="list-style-type: none"> - Engineer - Contractor 	Project completion
	4. The contractor is to water and maintain all planted vegetation until they are well established and / or to the end of the defects liability period and is to submit a method statement regarding this to the Engineer and MCM&E	<ul style="list-style-type: none"> - Contractor - MCM&E 	Project completion

⁴⁵ Appendix 11: Spill Contingency Plan

⁴⁶ This is site specific and will not apply to all developmental activities at the discretion of the MCM&E.

C.3. LAND REHABILITATION	1. An indigenous landscape plan would be required to be undertaken by a suitably qualified professional ⁴⁷ . The landscape plan must incorporate landscaping of storm water designs such as channels/dams. The landscape plan must be implemented and maintained throughout the life cycle of the development – including replacement of species that do not establish	- Engineer - Contractor - Applicant / land owner	Project completion
	2. All surfaces hardened due to construction activities are to be ripped and imported materials removed in consultation with the MCM&E and Contractor/s.	- Contractor - MCM&E	Project completion
	3. All rubble is to be removed from the site to an approved disposal area / landfill site approved by the Engineer. Burying of rubble on site is prohibited	- Engineer - Contractor	Project completion
	4. All litter is to be removed from the site and properly disposed of to a registered landfill site.	- Engineer - Contractor	Project completion
	5. Surfaces are to be checked for waste products from activities such as concreting or asphaltting and cleared in a manner approved by the Engineer	- Engineer - Contractor	Project completion
	6. All embankments are to be trimmed, shaped and re-vegetated to the satisfaction of the Engineer and the MCM&E	- Engineer - MCM&E	Project completion
	7. 6. The contractor, engineer and MCM&E are to check all watercourse and crossings to ensure that they are free from building rubbles, spoil materials and waste materials	- Engineer - MCM&E	Project completion
	8. On completion of all operations, the construction site shall be cleared of any contaminated soil, which must be handled in accordance with the Spill Contingency Plan ⁴⁸	- Contractor	During and after construction
C.4. MATERIALS AND INFRASTRUCTURE	1. Fences, barriers and demarcations associated with construction activities are to be removed from the site unless stated otherwise by the Engineer and / or Land owner	- Engineer - Applicant / land owner	Project completion
	2. All remaining stockpiles must be removed or spread on site as directed by the Engineer and the MCM&E	- Engineer - Applicant / Land owner	Project completion
	3. All remaining building materials must be disposed of at a registered landfill site. Waybills must be provided as proof of disposals	- Engineer - Applicant / Land owner	Project completion
	4. The contractor must repair any damage that the construction work has caused to neighbouring properties	- Engineer - Contractor - Applicant / Land owner	Project completion as instructed by the engineer
C.5. GENERAL	1. A closure meeting must be held on site between the Engineer, MCM&E, Contractor and Applicant / Land owner to approve all remediation activities and to ensure that the site has been restored to a condition approved by all parties involved	- Engineer - Contractor - Applicant / Land	On completion of project and rehabilitation

⁴⁷ To be determined by the Msunduzi Municipalities Environmental Management Unit or other relevant authority

⁴⁸ Appendix 11

		owner	processes
	2. Temporary roads must be closed and access across these blocked. These roads / access ways must be rehabilitated and re-vegetated (in accordance with the Rehabilitation Plan ⁴⁹) with Indigenous Plant Species ⁵⁰ . All Alien Plants Species found along these routes must be removed ⁵¹ .	- Engineer - Contractor - Applicant / Land owner	Project completion
	3. Access or haulage roads that were constructed across watercourse must be rehabilitated by removing temporary bridges and other material/s place in/near to watercourses. Re-vegetation of banks and/or streambeds must be undertaken and approved by the Engineer prior to commencement. Input must be provided by Msunduzi Municipalities Environmental management unit, DEDTEA and DW&S	- Engineer - Contractor	Project completion and during rehabilitation
	4. All areas where temporary services were installed are to be rehabilitated to the satisfaction of the engineer and MCM&E	- Engineer - MCM&E	Project completion and during rehabilitation

⁴⁹ Appendix 8

⁵⁰ Appendix 6

⁵¹ In accordance with appendix 5 & 7

12. EMPR SECTION D: DECOMMISSIONING PHASE⁵²

Decommissioning includes but is not limited to the demolition of buildings, removal of infrastructure, decommission of wells and flow lines, rehabilitation and re-vegetation. Areas disturbed by the project are to be rehabilitated to a stable, pollution free, landform with an indigenous self-sustaining vegetation cover. Rehabilitation must commence immediately when areas become available for rehabilitation purposes.

	ACTIVITY	MONITOR	FREQUENCY
D.1. POLLUTION CONTROL STRUCTURES	1. Break up all brick and concrete structures and remove waste to an appropriate disposal site (unless the material is proposed to be used as fill material for a new development ⁵³). If this is the case, this material must be stored appropriately (stockpiles must not be over 3 metres).	- Engineer - Contractor - MCM&E	During decommissioning
D.2. WASTE	1. Remove leftover materials from the site and either sell, auction, donate to the local community or transfer to the Contractor's base for appropriate disposal.	- Engineer - Contractor - MCM&E	During decommissioning
	2. Any construction debris, litter and domestic waste from the construction site during decommissioning must be transferred to an appropriate disposal site.	- Engineer - Contractor - MCM&E	During decommissioning
	3. No waste is to be burned on site - all waste is to be transferred to a permitted disposal site.	- Engineer - Contractor - MCM&E	During decommissioning
D.3. ALIEN VEGETATION	1. Existing alien vegetation must be removed from the entire property. During this process, it is imperative that indigenous vegetation is not removed or disturbed.	- Engineer - Contractor - MCM&E	During Decommissioning / emergence of alien species
	2. Follow-up controls for at least a year following rehabilitation to prevent spread into disturbed soils.		
D.4. EROSION	1. After decommissioning, bare soil must not be left exposed. If further development is not taking place within a week, exposed areas must either be dampened and covered with plastic, or planted with quick growing indigenous vegetation.	- Engineer - Contractor - MCM&E	During decommissioning
D.5. REHABILITATION	1. All areas affected by construction activities must be adequately rehabilitated with indigenous vegetation	- Engineer - Contractor - MCM&E	During decommissioning
	2. Monitor all rehabilitated areas for at least a year following the completion of rehabilitation	- Engineer	During

⁵² Must be done in consultation with the relevant business units within the Msunduzi Municipality

⁵³ This must be done in consultation with the relevant municipal business units

	works for failure of vegetation to establish and / or erosion. Immediately implement remedial measures as required.	- Contractor - MCM&E	decommissioning
	3. Cordon off rehabilitated areas and do not allow grazing or access into these areas until such time that re-vegetation was found to be successful.	- Engineer - Contractor - MCM&E	During decommissioning
D.6. INFRASTRUCTURE	1. All structures, infrastructure, roads, servitudes etc. not required for the post decommissioning use of the site should be dismantled and transported off-site on decommissioning.	- Engineer - Contractor - MCM&E	After construction During decommissioning

Appendix 1: Environmental Code of Conduct

The main objective of the EMPr is to ensure that all the workers, contractors and sub-contractors have an understanding of environmental issues and potential impacts on site activities. This Environmental Code of Conduct provides the basic rules that should be strictly adhered to. It is the responsibility of the Applicant / Land Owner to ensure that each contractor, sub-contractor and member of the workforce understand and adhere to the Code of Conduct.

a. ENVIRONMENTAL CODE OF CONDUCT

All persons are obliged to abide by the rules of this code of conduct.

b. ENVIRONMENTAL RULES

- Do not waste electricity, water or consumables.
- Only use authorised accesses.
- Do not litter.
- Dispose solid waste to the correct waste containers provided.
- Prevent pollution.
- Use the toilet facilities provided.
- Do not dispose contaminated waste water to the storm water or the environment.
- Immediately report any spillage from containers, plant or vehicles.
- Do not burn or bury any waste.
- Do not trespass onto private properties.
- Strictly leave all animals alone. Never tease, catch or set devices to trap or kill any animal.
- Never damage or remove any trees, shrubs or branches unless it forms part of working instructions
- Do not deface, draw or cut lettering or any other markings on trees, rocks or buildings in the area.
- Know the fire fighting procedure and locations of fire fighting equipment; and
- Know the environmental incident procedures.

We aim to continuously improve our environmental performance.

Management encourages each and every employee to report issues of concern or observations of potential hazards to their management and / or supervisors.

APPENDIX 2: COMPLAINTS REGISTER FORMAT

The following must be completed for each reported complaint. The Project Manager / Property Owner is to ensure that each complaint is addressed and followed up on within 7 days.

TIME & DATE	COMPLAINANT CONTACT INFORMATION			NATURE OF COMPLAINT	RESPONSE (Dealt with / pending etc.)	RESPONSIBLE PERSONS FOR RESPONSE	RECTIFICATION ACTION
	Name	Contact number	Address				

APPENDIX 3: ENVIRONMENTAL INCIDENTS RECORDING

All environmental incidents / issues of concern which occur on the site must be recorded in the following format.

Time	Date	Nature And Extent Of The Incident	Rectification measures	Person Responsible To Rectify Incident

Appendix 4: Materials Safety Data Sheet – Template

SECTION 1 - PRODUCT & COMPANY IDENTIFICATION

Tel:
Fax:

e-mail:
Web address:

Substance:

Product:

Product Use:

Creation Date:

Revision Date:

24 Hrs. Emergency Number:

In case of poisoning:

Poison Information Centre: 0800 888 444

Hospital: Greys Hospital: 033 8973000

: Northdale Hospital: 033 3879000

: Edendale Hospital: 0333954911

Poison Emergencies Enquires: 0800 888 444

In case of Spillage:

Contact No: 033 3860628 (DRIZIT ENVIRONMENTAL CC)

: 0800033911 or 0338455911 (Msunduzi Fire Department)

SECTION 2 - COMPOSITION / INFORMATION ON INGREDIENTS

Common Name:

Chemical Name:

CAS No:

Chemical Family:

Chemical Formula:

Molecular weight:

Use:

Components:

Active Ingredients:

Symbol:

Indication of danger:

Risk Phrases:

SECTION 3 - HAZARD IDENTIFICATION

Toxicity class:

Main Hazard:

Flammability:

Biological Hazard:

Eye Contact:

Skin Contact:

Ingestion:

Inhalation:

SECTION 4 - FIRST AID MEASURES AND PRECAUTIONS

This section must give clarity on how toxic the product is by ingestion or skin exposure and explain the precautions that must be taken in case of the following:

Inhalation:

Skin Contact:

Eye Contact:

Ingestion:

Advice to physician:

SECTION 5 - FIRE - FIGHTING MEASURES

Fire and explosion hazard:

Flash point:

Extinguishing agents:

Hazardous products of combustion:

Fire fighting:

Personal protective equipment:

SECTION 6 - ACCIDENTAL RELEASE MEASURES (SPILLAGE)

Personal precaution:

Environmental precautions:

Occupational spill:

SECTION 7 - HANDLING AND STORAGE REQUIREMENTS

Handling:

Avoid contact with eyes, prolonged contact with skin, and inhalation of spray and fumes. Handle product with caution. Use with adequate ventilation. Wash hands before eating, drinking, chewing gum, smoking or using toilet. Remove clothing immediately if the herbicide gets inside. Then wash skin thoroughly using a non-abrasive soap and put on clean clothing. Operators should change and wash clothing after use. Do not apply directly to areas where surface water is present or intertidal areas below the mean high water mark. Water used to clean equipment must be disposed of correctly to avoid contamination.

Storage:

Store in its original closed container in dry, cool, shaded, well-ventilated area, away from heat, sparks and other sources of ignition. Do not store with other pesticides, fertilizer, seeds, food stuff, and water supplies. Store away from incompatible substances. Product is incompatible with galvanised steel or unlined mild steel. Keep out of reach of unauthorized persons, children and animals. Local regulations should be complied with.

SECTION - 8 EXPOSURE CONTROL / PERSONAL PROTECTION

It is essential to provide adequate ventilation. The measures appropriate for a particular work site depend on how this material is used and on the extent of exposure. Ensure that control systems are properly designed and maintained. Comply with occupational safety, environmental, fire and other applicable regulations.

PERSONAL PROTECTIVE EQUIPMENT:

If engineering controls and work practices are not effective in controlling exposure to this material, then wear suitable personal protective equipment including approved respiratory protection.

Respirator:

Clothing:

Gloves:

Eye Protection:

Emergency eye wash:

SECTION 9 - PHYSICAL AND CHEMICAL PROPERTIES

Appearance:

Odour:

Explosive properties:

Oxidising properties:

pH:

Density:

Solubility in water:

Flash point:

Boiling point:

SECTION 10 - STABILITY AND REACTIVITY

Stability:

Dilution stability:

Storage stability:

Incompatibility:

Thermal decomposition:

SECTION 11 - TOXICOLOGICAL INFORMATION

Acute oral LD50:

Acute dermal LD50:

Acute inhalation LC50 (4 h):

Acute skin irritation:

Acute eye irritation:

Dermal sensitisation:

Carcinogenicity:

Mutagenicity:

SECTION 12 - ECOLOGICAL INFORMATION

Degradability:

Mobility:

Accumulation:

Ecotoxicology:

Birds:

Fish:

Bees:

Daphnia:

Earthworms:

Other Beneficial organisms:

SECTION 13 - DISPOSAL CONSIDERATION

Pesticide disposal:

Open dumping or burning of this pesticide is prohibited. Waste resulting from the use of this product cannot be reused or reprocessed. Never pour untreated waste or surplus products into public sewers or where there is any danger of run-off or seepage into water systems. Do not contaminate rivers, dams or any other water sources with the product or used containers. Comply with local legislation applying to waste disposal.

Container disposal:

Emptied containers retain vapour and product residues. Observe all labelled safeguards until container is destroyed. TRIPLE RINSE empty containers in the following manner: Invert the empty container over the spray or the mixing tank and allow to drain for at least 30 seconds after the flow has slowed down to a drip. Thereafter; rinse the

container three times with a volume of water equal to a minimum of 10% of that of the container: Add the rinsing's to the contents of the spray tank before destroying the container in the prescribed manner.

Do not re-use the empty container for any other purpose but destroy it by perforation and flattening and bury in an approved landfill site.

Prevent contamination of food, feed stuff, drinking water and eating utensils.

Comply with local legislation applying to waste disposal.

SECTION 14 - TRANSPORT INFORMATION

UN NUMBER:

Road Transport ADR/IRD:

Class:

Packing Group:

Shipping name:

Maritime Transport IMDG/IMO:

Class:

Packing Group:

Shipping name:

Considered a Marine Pollutant.

SECTION 15 - REGULATORY INFORMATION

Symbol:

Indication:

Risk phrases:

R 20/22 Harmful by inhalation

R 36 Irritating to eyes

R 52 Harmful to aquatic organisation

R 54 Toxic to flora

Safety phrases:

S 2 Keep out of reach of children

S 2425 Avoid contact with skin and eyes

S 36/37/39 Wear suitable protective clothing, gloves and eye/face protection

S 45 In case of accident or if you feel unwell, seek medical advice immediately (Show the label where possible)

S 61 Avoid release to the Environment

SECTION 16 - OTHER INFORMATION

Packaging and Labelling:

Disclaimer:

Appendix 5: Alien Invasive Plant List

CARA AND NEMBA Category Descriptions:

CARA (Conservation of Agricultural Resources Act, 1983) amended in March, 2001:

Category 1: Remove and destroy.

Category 2: Permit required. A demarcation permit is required to import, possess, grow, breed, move, sell, buy or accept plants as a gift.

Category 3: No planting. No selling. No importing, breeding, growing, moving, selling or buying, but existing plants may remain in your garden if kept under control.

NEM: BA (National Environmental Management: Biodiversity

Act, 2004) – Alien and Invasive Species Regulations, 19 July 2013:

Category 1a: Remove and destroy. Listed invasive species that require compulsory control.

Category 1b: Remove and destroy. Listed invasive species that require control by means of an invasive species management programme.

Botanical Name	Common name	CARA Category	NEM:BA
<i>Plectranthus comosus</i>	Abyssinian coleus, Woolly plectranthus	3	
	<i>Ageratum</i> spp:- see <i>Ageratum/ Invading /Mexican</i>		
<i>Ageratum Conyzoides</i>	<i>Ageratum/Invading Ageratum</i>	1	
<i>Sorghum halapense</i>	Aleppo grass/ Johnson grass	2	
<i>Pinus halepensis</i>	Aleppo pine	2	
<i>Rubus cuneifolius</i>	American brumble	1	
<i>Triplaris Americana</i>	Ant tree, <i>Triplaris</i>	1	
<i>Paraserianthes lophanta</i>	Australian Albizia/ Stink bean	1	
<i>Acacia melanoxylon</i>	Australian blackwood	2	
<i>Pttosporum undulatum</i>	Australian chees wood/ Sweet pittosporum	1	
<i>Leptospermum laevigatum</i>	Australian myrtle	1	
<i>Grevilea robusta</i>	Australian silky oak	3	
<i>Azolla filiculoides</i>	<i>Azolla /red water fern</i>	1	
<i>Acacia baileyana</i>	Baileys Wattle	3	
<i>Passiflora mollisima</i>	Bananapoka, Bananadilla	1	
<i>Casuarina cunninghamiana</i>	Beef wood	2	none
<i>Phytolacca dioica</i>	Belhambra	3	none
<i>Eucalptus sideroxylon</i>	Black ironbark/ Red ironbark	2	
<i>Robinia pseudoacacia</i>	Black Locust	2	none
<i>Rivina humilis</i>	Bloodberry/ <i>Rivina</i>	1	
<i>Echium Vulgare</i>	Blue echium	1	
<i>Passiflora caerulea</i>	Blue Passion Flower	1	
<i>Psidium guineense</i>	Brazillian Guava	3	
<i>Schinus terebinthifolius</i>	Brazillian pepper tree	1	
<i>Anredera cordifolia</i>	Bridal wreath	1	
<i>Salix fragilis</i>	Brittle willow	2	
<i>Solanum mauritianum</i>	Bugweed	1	none
<i>Achyranthes aspera</i>	Burweed	1	
<i>Bauhinia purpurea</i>	Butterfly orchid tree	3	
	<i>Cactus/ Prickly pear spp</i>		
	<i>Imbricate/jointe/Long spine/rosea</i>		
	<i>Saucepan/Moon/ Harrisa cactus</i>		
	<i>Cochineal/Creeping/ Droping/Large mission/ Large round-leaved/ Small round-leaved/ Sweet prickly pear/</i>		

	<i>Pest pear of Australia</i>		
<i>Ligustrum ovalifolium</i>	Californian Privet	3	
<i>Alhagi maurorum</i>	Camel thorn bush	1	
<i>Cinnamomum camphora</i>	Camphor tree	1	
<i>Elodea Canadensis</i>	Canadian Water Weed	1	
<i>Pinus canariensis</i>	Canary pine	2	
	<i>Cassia SPPS</i>		
	<i>Peanut Butter/ Rambling Cassia</i>		
<i>Ricinus communis</i>	Castor oil plant	2	none
<i>Macfadyena unguis-cati</i>	Cat's Claw Creeper	1	none
	<i>Cestrum spps:- seeCrimson /inkberry/ Orange/ yellow</i>		
<i>Bryophyllum delagoense</i>	Chandelier Plant	1	
<i>Lantana camara</i>	Cherry Pie/Tick berry/ Lantana	1	
<i>Cestrum parqui</i>	Chilean Cestrum	1	
<i>Ligustrum sinense</i>	Chinese Privet	3	none
<i>Tamarix chinensis</i>	Chinese Tamarisk	3	
<i>Ligustrum lucidum</i>	Chinese Wax-leaved Privet	3	none
<i>Pinus Roxburghii</i>	Chir Pine/ Longifolia Pine	2	
<i>Chromolaena odorata</i>	Chromolaena /Trifid weed/ Paraffin Bush	1	
<i>Orobanche minor</i>	Clover Broomrape/Lesser Broomrape	1	
<i>Pinus pinaster</i>	Cluster Pine	2	
<i>Opuntia monacanthi</i>	Chochineal/ DroppingPrickly Pear	1	
	<i>Cocklebur spp</i>		
	<i>Large/ Spiney Cocklebur</i>		
<i>Cuscuta campestris</i>	Common dodder	1	none
<i>Morus alba</i>	Common Mulberry/ White Mulberry	3	
<i>Ligustrum vulgare</i>	Common Privet	3	
<i>Datura stramonium</i>	Common thorn Apple	1	none
<i>Ardisa crenata</i>	Coral Bush/ Coralberry	1	
	<i>Cotoneaster spps:- see</i>		
	<i>Cotoneaster/ Silver-leaf</i>		
<i>Cotoneaster franchetii</i>	Cotoneaster	3	none
<i>Salix fragilis</i>	Crack Willow, Brittle Willow	2	
<i>Opuntia humifusa</i>	Creeping/ Large floweredprickly pear	1	
<i>Cestrum elegans</i>	CrimsonCestrum	1	
<i>Argentina adenophora</i>	Crofton weed	1	
<i>Parthenium hysterophorus</i>	Demoina Weed/ Parthenium/Feverfew	1	
<i>Egeria densa</i>	Dense Water Weed	1	
<i>Solanum Sisymbriifolium</i>	Dense-thorned bitter apple/ Wild tomato		
<i>Pasiflora suberosa</i>	Devil's Pumki/ Indigo Berry	1	
<i>Datura innoxia</i>	Downy Thorn Apple	1	none
<i>Opuntia monacantha</i>	Drooping/ Cochineal Prickly Pear	1	none
<i>Psidium X durbanensis</i>	Durban Guava	1	
<i>Rosa rubiginosa</i>	Eglantine/ Sweetbriar	1	
<i>Rubus fruticosus</i>	European Blackberry	2	
	<i>Eucalyptus gum spps:-see gum spps</i>		
<i>Ulex europaeus</i>	European Gorse	1	
<i>Albizia procera</i>	False Lebbeck	1	
<i>Pennisetumvillosum</i>	Feathertop	1	
<i>Convolvulus arvensis</i>	Field Bindweed/ Wild Morning-glory	1	
	<i>Firethorn spps:- see Himalayan/ Yellow Firethorn</i>		
<i>Lilium formosanum</i>	Formosa/St Joseph's/ Trumpet lily	3	

<i>Penisetum setaceum</i>	Fountain Grass	1	none
<i>Arundo donax</i>	Giant reed/ Spanish reed	1	none
<i>Mimosa pigra</i>	Giant Sensitive plant	3	
	Ginger Lilies:- See Kahili/Red/White/Yellow ginger		
<i>Acacia pycnantha</i>	Golden Wattle	1	
<i>Passiflora Subpeltata</i>	Granadina	1	
<i>Acacia deecurrens</i>	Green Wattle	2	
<i>Eucalyptus paniculata</i>	Grey Ironbark	2	
<i>Populus X canescens</i>	Grey poplar/ Matchwood poplar	2	none
	Guava spps:-see Brazillian/ Durban/Guava/Strawberry guava		
<i>Psidium guajava</i>	Guava	2	
	Gum spps:-see karri/red river/Rose/Saligna/ Spider/ Sugar Black/Grey/ Red ironbark		
	Hakea spps:-see sweet/Rock/Silky hakea		
<i>Harrisia martinii</i>	Harrisia cactus/Moon cactus	1	
<i>Pyracantha crenulata</i>	Himalayan firethorn	3	1b
<i>Lepidium draba</i>	Hoary Cardaria/ Pepper-cress/White top	1	
<i>Gledistia tracanthos</i>	Honey locust/ Sweet locust	2	none
<i>Prosopis glandulosa</i>	Honey mesquite	2	
<i>Casuarina equisetifolia</i>	Horsetail tree	2	
<i>Opuntia imbricate</i>	Imbricate prickly pear	1	
<i>Opuntia imbricate</i>	Imbricate prickly pear/Cactus	1	
<i>Litsea glutinosa</i>	Indian Laurel	1	
<i>Canna indica</i>	Indian shot	1	
<i>Passiflora suberosa</i>	Indigo berry/Devil's Pumpkin	1	
<i>Cestrum laevigatum</i>	Inkberry	1	
<i>Ageratum conyzoides</i>	Invading Ageratum/Ageratum	1	
<i>Jacaranda mimosifolia</i>	Jacaranda	3	
<i>Syzygium cumini</i>	Jambolan	3	
<i>Ligustrum japonicum</i>	Japanese wax-leaved privet	3	
<i>Sorghum halepense</i>	Johnson grass/Aleppo Grass	2	Protecte d
<i>Opuntia aurantiaca</i>	Jointed cactus	1	
<i>HedychiumGardnerianum</i>	Kahili ginger lily	1	
<i>Acacia paradoxa</i>	Kangaroo wattle	1	
<i>Salvinia molesta</i>	Kariba weed	1	
<i>Eucalyptus diversicolor</i>	Karri	2	
<i>Pueraraia lobata</i>	Kudzu vine	1	
<i>Lantana camara</i>	Lantana, Tickberry/Cherry pie	1	1b
<i>Xanthium strumarium</i>	Large cocklebur	1	none
<i>Opuntia humifusa</i>	Large flowered/creeping prickly pear	1	
<i>Opuntia spenulifera</i>	Large round-leavedprickly pear/Saucepan	1	
<i>Datura ferox</i>	Large thorn Apple	1	
<i>Albizia lebbeck</i>	Lebbeck tree	1	
<i>Orobanche minor</i>	Lesser broomrape/ Clover broomrape	1	
<i>Leucaena leucocephala</i>	Leucaena	2	none
<i>Pinus taeda</i>	Loblolly pine	2	
<i>Opuntia exaltata</i>	Long spine cactus	1	
<i>Pinus roxburghii</i>	Longifolia pine/ Chir pine	2	
<i>Acacia longifolia</i>	Long leaved-wattle	1	
<i>Eriobotrya japonica</i>	Loquat	3	
<i>Cuscuta suaveolens</i>	Lucerne dodder	1	

<i>Anredera cordifolia</i>	Madeira vine/Bridal wreath	1	
<i>Myoporum tenuifolium, montanum</i>	Manatoka	3	
<i>Populus X canescens</i>	Matchwood poplar/Grey poplar	2	
<i>Caesalpinia decapetala</i>	Mauritius thorn	1	
	Mesquite spps:-see Honey/ Velvet mesquite		
<i>Ageratumhoutonianum</i>	Mexican Ageratum	1	
	Mexican poppy spps:- see Yellow-flowered/ White-flowered		
	Mexican poppy		
<i>Tithonia diversifolia</i>	Mexican Sunflower	1	
<i>Opuntia ficus-indica</i>	Mission Prickly pear, Sweet Prickly pear	1	
<i>Ageratina riparia</i>	Mistflower	1	
<i>Montanoa hibiscifolia</i>	Montanoa, tree daisy	1	
<i>Pinus radiata</i>	Monterey pine/ Radiata pine	2	
<i>Cytisusmonspeulanus</i>	Montpellier broom	1	
<i>Harrisia martini</i>	Moon cactus/Harrisia cactus	1	
<i>Ipomoea alba</i>	Moonflower	1	
<i>Ipomoea purpurea</i>	Morning Glory(annual)	3	1b
<i>Ipomoea indica</i>	Morning Glory(perennial)	1	
<i>Araujia sericifera</i>	Moth catcher	1	none
<i>Nassella trichotoma</i>	Nassella tussock	1	
<i>Metrosiderosexelsa</i>	New Zeland Christmas tree	3	
<i>Atriplexnummularia</i>	Old man saltbush	2	
<i>Nerium oleander</i>	Oleander	1	
<i>Cestrum aurantiacum</i>	Orange cestrum or Yellow cestrum	1	
	Orchid tree spps:- see Orchid/Butterfly orchid		
<i>Bauhinia variegata</i>	Orchid tree	3	
<i>Cordaderia jubata</i>	Pampas grass	1	none
<i>Cortaderia seloana</i>	Pampas grass	1	none
<i>Chromolaena odorata</i>	Paraffin bush/Chromolaena/Triffid weed	1	
<i>Myrophyllum aquaticum</i>	Parrot's feather	1	
<i>Parthenium hyperophorus</i>	Parthenium/Demoina weed/Feverfew	1	
<i>Echium plantagineum</i>	Patterson's curse	1	
<i>Pinus patula</i>	Patula pine	2	
<i>Senna didymobotrya</i>	Peanut butter cassia	3	
<i>Acacia podalyriifolia</i>	Pearl acacia	3	none
<i>Acacia elata</i>	Pepper tree wattle	3	
<i>Lepidium draba</i>	Pepper-cress/Hoary cardaria/White top	1	
<i>Pereskia acuelata</i>	Pereskia/Barbados gooseberry	1	
<i>Melia azedarach</i>	Persianlilac, Syringa	3	
<i>Opuntia stricta</i>	Pest pear of Australlia	1	
<i>Pontenderia cordata</i>	Pickerel weed	3	
	Pine spps:- see Aleppo/ Canary/Chir/Cluster/Lobloly/Longifolia/ Monterey/Radiata/ Patula pine		
<i>Tamarix ramosissima</i>	Pink tamarisk	3	
<i>Eugenia uniflora</i>	Pitanga/Surinam cherry	1	
<i>Campuloclinium macrocephalum</i>	Pom Pom weed	1	none
	Poplar spps:- see Grey/ White/ Match wood poplar		
<i>Acacia saligna</i>	Port Jackson willow	2	
<i>Solanum seaforthianum</i>	Potato creeper	1	none
	Privet spps:- see Chinese wax-leaved/Japanese wax-leaved/ Californian/Chinese/ Common privet		

	<i>Prickly pear/Cactus spp:- see cactus</i>		
<i>Lythrum salicaria</i>	<i>Purple Loosestrife</i>	1	
<i>Cereus jamacaru</i>	<i>Queen of the night</i>	1	<i>none</i>
<i>Pinus radiata</i>	<i>Radiata pine/ Monterey pine</i>	2	
<i>Senna bicapsularis</i>	<i>Rambling cassia</i>	3	<i>none</i>
<i>Acacia Cyclops</i>	<i>Red eye</i>	2	
<i>Hedychium connineum</i>	<i>Red ginger lily</i>	1	
<i>Eucalyptus Sideroxylon</i>	<i>Red ironbark/ Black ironbark</i>	2	
<i>Eucalyptus camaldulensis</i>	<i>Red River gum</i>	2	<i>none</i>
<i>Sesbania punicea</i>	<i>Red sesbania</i>	1	?
<i>Tithonia rotundifolia</i>	<i>Red sunflower</i>	1	<i>none</i>
<i>Azolla filiculoides</i>	<i>Red Water fern/ Azolla</i>	1	
<i>Rivina humilis</i>	<i>Rivina/Bloodberry</i>	1	
<i>Hakea gibbosa</i>	<i>Rock hakea</i>	1	
<i>Syzygium jambos</i>	<i>Rose apple</i>	3	
<i>Eucalyptus grandis</i>	<i>Rose Gum/ Saligna gum</i>	2	
<i>Opuntia fulgida</i>	<i>Rosea cactus</i>	1	
<i>Eucalyptus grandis</i>	<i>Saligna gum/Rose Gum</i>	2	
<i>Opuntia spinulifera</i>	<i>Saucepan cactus/ Largeround-leaved</i>	1	
<i>Cytisus scoparius</i>	<i>Scotch broom</i>	1	
<i>Cirsium vulgare</i>	<i>Scotch thistle/Spear thistle</i>	1	
<i>Acacia implexa</i>	<i>Screw-pod wattle</i>	1	
<i>Hakea sericea</i>	<i>Silky hakea</i>	1	
<i>Acacia dealbata</i>	<i>Silver Wattle</i>	2	<i>none</i>
<i>Solanum elaeagnifolium</i>	<i>Silver- leaf bitter apple</i>	1	
<i>Cotoneaster pannosus</i>	<i>Silver-leaf cotoneaster</i>	3	
<i>Thelechitonia/Wedelia trilobata</i>	<i>Singerpore Daisy</i>	1	
<i>Agave sisalana</i>	<i>Sisal hemp/Sisal</i>	2	
<i>Agave sisalana</i>	<i>Sisal/Sisal hemp</i>	2	
<i>Pinus ellioti</i>	<i>Slash pine</i>	2	
<i>Opuntia lindheimeri</i>	<i>Small round –leaved prickly pear</i>	1	
<i>Spartium junceum</i>	<i>Spanish broom</i>	1	
<i>Arundo donax</i>	<i>Spanish reed, Giant reed</i>	1	
<i>Cirsium vulgare</i>	<i>Spear thistle, Scotch thistle</i>	1	
<i>Eucalyptus lehmannii</i>	<i>Spider gum</i>	2	
<i>Myriophyllum spicatum</i>	<i>Spiked water-milfoil</i>	1	
<i>Xanthium spinosum</i>	<i>Spiny Cocklebur</i>	1	
<i>Atriplex lindleyi</i>	<i>Sponge-fruit Saltbush</i>	3	
<i>Hypericum perforatum</i>	<i>St. John's Wort/Tipton weed</i>	2	
<i>Lilium formosanum</i>	<i>St. Joseph's/Trumpet/Formosa Lily</i>	3	
<i>Paraserianthes lophanta</i>	<i>Stink Bean/Australian Albizia</i>	1	
<i>Psidium cattleianum</i>	<i>Strawberry Guava</i>	3	
<i>Eucalyptus cladocalyx</i>	<i>Sugar Gum</i>	2	
	<i>Sunflower spp:- Mexican/ Red Sunflower</i>		
<i>Eugenia uniflora</i>	<i>Surinam Cherry/Pitanga</i>	1	
<i>Hakea drupacea</i>	<i>Sweet hakea</i>	1	
<i>Gledistia triacanthos</i>	<i>Sweet locust/Honey Locust</i>	2	
<i>Pittosporum undulatum</i>	<i>Sweet pittosporum/Australian Cheesewood</i>	1	
<i>Opuntia ficus-indica</i>	<i>Sweet Prickly pear/ Mision Prickly pear</i>	1	<i>none</i>
<i>Rosa rubiginosa</i>	<i>Sweetbriar/Eglantine</i>	1	
<i>Nephrolepis exaltata</i>	<i>Sword fern</i>	3	
<i>Melia Azedarach</i>	<i>Syringa/Persian lilac</i>	3	<i>none</i>

	<i>Tamarisk spps:- see Chinese/Pink tamarisk</i>		
	<i>Thorn apple spps:-see common/Downey/Large thorn apple</i>		
<i>Lantana camara</i>	<i>Tickberry/Cherry pie/Lantana</i>	1	
<i>Hypericum perforatum</i>	<i>Tipton weed/St John's wort</i>	2	
<i>Tipuana tipu</i>	<i>Tipu tree</i>	3	<i>none</i>
<i>Toona ciliate</i>	<i>Toon tree</i>	3	
<i>Echinopsis spachiana</i>	<i>Torch cactus</i>	1	
<i>Montanoa hibiscifolia</i>	<i>Tree daisy/Montanoa</i>	1	
<i>Ailanthus altissima</i>	<i>Tree-of-heaven</i>	3	<i>none</i>
<i>Chromolaena odorata</i>	<i>Triffid weed/Chromolaena/Paraffin bush</i>	1	
<i>Triplaris Americana</i>	<i>Triplaris/Ant tree</i>	1	
<i>Lilium formosanum</i>	<i>Trumpet/St.Joseph's/Formosa lily</i>	3	
<i>Prosopis velutina</i>	<i>Velvet mesquite</i>	2	
<i>Eichhornia crassipes</i>	<i>Water hyacinth</i>	1	
<i>Pistia stratiotes</i>	<i>Water lettuce</i>	1	
<i>Rorippa narstutium-aquaticum</i>	<i>Watercress</i>	2	
	<i>Wattle spps:- seeBailey's/Black green/Golden/Kangaroo/Long-leaved/Pepper tree/Red/Screw-pod/ Silver wattle/ Pearl acacia</i>		
<i>Rhus succedanea</i>	<i>Wax tree</i>	1	
<i>Salix babylonica</i>	<i>Weeping willow</i>	2	<i>none</i>
<i>Hedychium coronarium</i>	<i>White Ginger lily</i>	1	
<i>Morus alba</i>	<i>White Mulberry/Common Mulberry</i>	3	
<i>Populus alba</i>	<i>White poplar</i>	2	
<i>Lepidium draba</i>	<i>White top/Hoary cardaria/Pepper-cress</i>	1	
<i>Nassella tenuissima</i>	<i>White tussock</i>	1	
<i>Argemone ochroleuca</i>	<i>White-flowered Mexican poppy</i>	1	<i>none</i>
<i>Convolvulus arvensis</i>	<i>Wild morning glory/Field bindweed</i>	1	
<i>Nicotiana glauca</i>	<i>Wild tobacco</i>	1	
<i>Solanum sisymbriifolium</i>	<i>Wild tomato/Dense –thorned bitter apple</i>	1	
	<i>Willow spps:-see Brittle/ crack/Weeping willow</i>		
<i>Plectranthus comosus</i>	<i>Woolly plecthranthus/Abyssinian coleus</i>	3	
<i>Temoca stans</i>	<i>Yellow bells</i>	1	<i>none</i>
<i>Cestrum aurantiacum</i>	<i>Yellow cestrum or Orange cestrum</i>	1	
<i>Pyracantha angustifolia</i>	<i>Yellow firethorn</i>	3	
<i>Hedychium flavescens</i>	<i>Yellow Ginger lily</i>	1	
<i>Thevetia peruviana</i>	<i>Yellow oleander</i>	1	
<i>Argemone mexicana</i>	<i>Yellow –flowered Mexican poppy</i>	1	

Appendix 6: Indigenous Plant List

BOTANICAL NAME	COMMON NAME	EVERGREEN/DECIDUOUS	FROST RESISTANT	DROUGHT RESISTANT	AGGRESSIVE ROOTS	GROWTH RATE/YR	SIZE	PLANTING SITES	EDIBLE FRUIT
Acacia caffra	Common Hook Thorn	D	Yes	Yes	Yes	Medium 700-900 mm	Medium 7-10m	Stream banks, Open space	
Acacia karroo	Sweet Thorn	Semi/D	Yes	Yes	Yes	Fast 1m	Medium 4-8m	Stream banks, Open space	
Acacia robusta	Sple ndid Thorn	D	Moderate	Moderate	No	Fast 1m	Medium 10m	Stream Banks, Open space, Moist areas	
Acacia sieberiana	Paperbark Thorn	D	Yes	Yes	No	Fast 1m	Large 10-12m	Open space	
Acokanthera oppositifolia	Common Poison-bush	E	Yes	Yes	No	Medium 500-700mm	Small 2-5m	All	
Apodytes dimidiata	White Pear	E	Yes	Yes	No	Medium 700mm	Medium 4-7m	Open space, Screen, Avenue	
Bauhinia galpinii	Pride-of-De Kaap	E	Yes	Yes	No	Fast 1m	Shrub 3-4m	Screen, Hedge	
Bolusanthus speciosus	Tree Wisteria	D/E	Moderate	Yes	No	Fast 800mm	Medium 4-8m	Avenue, Open space	
Bowkeria verticillata	Natal Shell-flower Bush	E	Yes	Moderate	No	Medium 500mm	Shrub 3-5m	Stream bank, screen	
Brachylaena discolor	Coast Silver Oak	E	Yes	Moderate	No	Very Fast 1,5m	Shrub 3-6m	Screen, Hedge	
Buddleja auriculata	Weeping Sage	E	Yes	Yes	No	Fast 1m	Shrub 2-3m	Stream bank	
Buddleja saligna	False Olive	E	Yes	Yes	No	Fast 800mm	Medium 2-7m	Stream banks, Open space, Screen	
Budleja salviifolia	Sagewood	E	Yes	Yes	Yes	Fast 600-800mm	Medium 4-8m	Stream banks, Rehabilitation sites	
Burchellia bubalina	Wild Pomegranate	E	Moderate	Moderate	No	Slow 300mm	Small 2-5m	Feature, Filler	
Calodendrum capense	Cape Chestnut	D/E	Moderate	Moderate	No	Medium 600mm	Large 8-10m	Street tree, Parking lots, Open Space, Parks	
Carissa macrocarpa	Amatungulu	E	No	Yes	No	Fast 700mm	Small 2-3m	Hedge, Screen	Yes
Cassine aethiopica	Kooboo-berry	E	Moderate	Yes	No	Medium 300-400mm	Small 3-4m	Filler, Screen	
Celtis africana	White Stinkwood	D	Moderate	Moderate	No	Fast 1-1,5m	Large 10-12m	Street tree, Open space, Parks, Avenue	
Chrysanthemoides monilifera	Bush-tick Berry	E	Moderate	No	No	Fast 1m	Small 1-3m	Filler, Screen	Yes
Clausena anisata	Horsewood	E	Moderate	Moderate	No	Fast 800mm	Small 3-4m	Filler, Stream banks	

Clerodendrum glabrum	Cat's Whiskers	D	Yes	Moderate	No	Fast 1.5m	Medium 5-8m	Stream banks, Rehabilitation sites	
Coddia rudis	Small Bone-apple	E	Moderate	Moderate	No	Med 400mm	Small 1-3m	Fill, Open space, Stream banks	
Combretum erythrophyllum	River Bushwillow	D	Yes	Yes	No	Fast 1m	Medium 6-10m	Stream banks, Street tree, Open space (moist area)	
Combretum kraussii	Forest Bushwillow	E	Yes	Moderate	No	Moderate	Large 5-20m	Verge, Open Space, Stream banks	
Combretum molle	Velvet Bushwillow	D	Moderate	Yes	No	Slow 400mm	Medium 4-8m	Rockery (Hot, dry area)	
Commiphora harveyi	Red-stem Corkwood	D	No	Yes	No	Fast 1m	Medium 5-10m	Rockery (Hot, dry), Verge Street tree	
Commiphora woodii	Forest Corkwood	D	No	No	No	Fast 1m	Large 8-12m	Stream banks, Forest, Verge (cool, moist area)	
Croton sylvaticus	Forest Fever-berry	D	Moderate	No	No	Fast 1,2m	Large 7-20m	Open space, Stream banks, Avenue/street tree	
Cussonia natalensis	Rock Cabbage Tree	D	Moderate	Moderate	No	Fast 1m	Medium 5-7m	Feature, Rockery (Hot, dry area)	
Dais cotinifolia	Pompon Tree	D/E	Moderate	No	No	Fast 1m	Medium 4-7m	Street tree, Stream banks, Open space	
Diospyros austro-africana	Fire-sticks	E	Yes	Yes	No	Slow 400mm	Small 2-3m	Rehabilitation sites, Stream banks	
Diospyros lycioides	Bluebush	D	Yes	Yes	No	Medium 600mm	Medium 2-7m	Filler, Rehabilitation sites	
Diospyros whyteana	Bladder-nut	E	Moderate	Moderate	No	Medium 600mm	Small 2-3m	Fill (full sun), Screen, Hedge	
Dodonaea angustifolia	Sand Olive	E	Yes	Yes	No	Fast 1m	Small 2-5m	Screen, Hedge	
Dombeya rotundifolia	Wild Pear	D	Moderate	Yes	No	Fast 1m	Medium 4-5m	Feature, Filler, Open space	
Dovyalis caffra	Kei-apple	E	Moderate	Yes	No	Medium 600mm	Medium 3-4m	Feature, Filler, Open space	Yes
Duvernoia adhatodoides	Pistol Bush	E	No	No	No	Fast 1m	Small 2-3m	Filler, Screen	
Ehretia rigida	Puzzle Bush	D	Yes	Yes	No	Fast 1m	Small 2-4m	Filler, Screen	Yes
Ekebergia capensis	Cape Ash	E	Moderate	Moderate	No	Fast 800mm	Large 10-12m	Street tree (moist), Avenue, Parking lot	
Erythrina lysistemon	Common Coral Tree	D	Moderate	Moderate	Yes	Fast 1,5m	Medium 5-7m	Feature, Open space	
Euclea crispa	Blue Guarri	E	Yes	Yes	No	Medium 500mm	Medium 2-4m	Screen, Pioneer, Rehabilitation sites	
Ficus natalensis	Natal Fig	E/D	No	No	Yes	Fast 1-1,5m	Large 10-12m	Stream banks	
Ficus sur	Broom Cluster Fig	E/D	Moderate	No	Yes	Fast 1,5-2m	Large 10-12m	Stream banks, Open space (wet areas)	Yes

Grewia lasiocarpa	Forest Raisin	E/D	Yes	No	No	Fast 1,2m	Small 3-5m	Screen	Yes
Grewia occidentalis	Cross-berry	E/D	Yes	Yes	No	Fast 1,5m	Small 2-3m	Screen, Filler, Rehabilitation sites (hardy)	Yes
Greyia sutherlandii	Natal Bottlebrush	E/D	No	No	No	Medium 700mm	Medium 2-4m	Feature (cool, moist area)	
Halleria lucida	Tree Fuchsia	E	Moderate	Moderate	No	Fast 900mm	Medium 3-4m	Screen, Filler	
Heteromorpha arborescens	Parsley Tree	D	Yes	Yes	No	Fast 1,5m	Large 5-10m	Feature (Bark)	
Heterophyxis natalensis	Lavender Tree	E/D	Moderate	Moderate	No	Fast 800mm	Medium 4-6m	Feature, Filler, Street tree	
Hippobromus pauciflorus	False Horsewood	E	Moderate	Yes	No	Medium 700mm	Shrub 2-4m	Screen	
Hypericum revolutum	Curry Bush	E	Yes	Moderate	No	Medium 800mm	Shrub 2-3m	Screen, Filler	
Ilex mitis	Cape Holly	E	Yes	No	No	Fast 900mm	Medium 7-10m	Stream banks, Street tree	Yes
Jasminum multipartitum	Wild Jasmine	E/D	Moderate	Yes	No	Fast 1m	Climber	Screen, Filler	
Kiggelaria africana	Wild Peach	E/D	Yes	Moderate	No	Fast 1m	Medium 5-8m	Street tree, Open space	
Loxostylis alata	Tarwood	E	Moderate	Moderate	No	Medium 700mm	Medium 4-5m	Screen, Open space, Street tree (small)	
Mackaya bella	River Bells	E	No	No	No	Fast 1m	Small 2-3m	Screen, Filler (moist, shady area)	
Maerua rosmarinoides	Needle-leaved Bush- cherry	E	Moderate	Moderate	No	Slow 300mm	Small 2-3m	Filler	
Maesa lanceolate	False assegai	E	Moderate	Moderate	No	Fast 1,5m	Medium 3-5m	Pioneer (moist areas)	
Maytenus acuminata	Silky Bark	E	Yes	Moderate	No	Medium 500mm	Medium 3-5m	Pioneer, Screen (dry area)	
Millettia grandis	Umzimbeet	E	Yes	Moderate	No	Fast 800mm	Large 8-12m	Street tree, Park	
Myrsine africana	Cape Myrtle	E	Yes	Moderate	No	Medium 400mm	Small 1,5-2m	Screen, Filler	
Ochna natalitia	Natal Plane	D	Moderate	Moderate	No	Slow 500mm	Small 1-2m	Filler, Screen	
Ochna serrulata	Carnival Bush	D	Moderate	Moderate	No	Slow 500mm	Small 1-2m	Filler, Screen	
<i>Olea europaea</i> subsp. <i>africana</i>	Wild Olive	E	Yes	Yes	Yes	Medium 800mm	Medium 5-7m	Rehabilitation sites (harsh areas)	Yes
Olinia emarginata	Mountain Hard Pear	E	Yes	No	No	Medium 500mm	Medium 5-10m	Stream banks, Street tree (moist areas)	
Ozoroa paniculosa	Common Resin Tree	D/E	Moderate	Moderate	No	Medium 500mm	Medium 3-5m	Open space	

<i>Pappea capensis</i>	Jacket-plum	E/D	Yes	Yes	No	Medium 500mm	Medium 5-6m	Filler, Open space	Yes
<i>Pavetta lanceolata</i>	Forest Bride's Bush	E	Moderate	No	No	Slow 400mm	Small 2-3m	Screen, Filler	
<i>Peddiea africana</i>	Green Flower Tree	E	Moderate	Moderate	No	Fast 1m	Small 2-3m	Filler, Feature	
<i>Phoenix reclinata</i>	Wild Date Palm	E	Moderate	Moderate	Yes	Medium	Medium 3-6m	Stream bank stabilization	Yes
<i>Pittosporum viridiflorum</i>	Cheesewood	E	Yes	Moderate	No	Medium 500mm	medium 3-6m	Stream banks, Open space	
<i>Polygala myrtifolia</i>	September Bush	E	Moderate	Yes	No	Fast 1m	Small 2-3m	Screen, Hedge, Filler	
<i>Protorhus longifolia</i>	Red Beech	E	Moderate	Yes	No	Medium 800mm	Medium 6-10m	Screen, Feature, Open space (moist areas)	
<i>Ptaeroxylon obliquum</i>	Sneezewood	D	Moderate	Yes	No	Medium 600mm	Medium 7-10m	Avenue, Street tree	
<i>Rapanea melanophloeos</i>	Cape Beech	E	Moderate	Moderate	No	Medium 500mm	Medium 3-8m	Feature, Stream banks (cool areas) Forest	
<i>Rhamnus prinoides</i>	Dogwood	E	Yes	Moderate	No	Medium 800mm	Small 2-4m	Stream banks (moist areas) Forest	Yes
<i>Rhus chirindensis</i>	Red Currant	D/E	Moderate	Yes	No	Fast 1m	Medium 6-10m	Open space, Stream banks, Parks	
<i>Rhus dentate</i>	Nana-berry	D	Yes	Moderate	No	Medium 700mm	Medium 3-4m	Open space, Feature, Stream banks	
<i>Rhus lucida</i>	Glossy Currant	E	Moderate	Yes	No	Fast 1m	Medium 4-6m	Open space, Parks (dry areas)	
<i>Rhus pentheri</i>	Common Crow-berry	E	Yes	Yes	No	Fast 1m	Medium 3-5m	Screen, Filler	
<i>Rhus rehmanniana</i>	Blunt-leaved Currant	E/D	Yes	Yes	No	Medium 500mm	Medium 3-5m	Screen, Rehabilitation sites	
<i>Rothmannia capensis</i>	Candlewood	E	Moderate	Moderate	No	Medium 500mm	Medium 5-8m	Feature (moist areas)	
<i>Rothmannia globosa</i>	September Bells	E	Moderate	Moderate	No	Medium 500mm	Medium 4-7m	Feature, Filler (moist areas)	
<i>Salix mucronata</i> subsp. <i>Woodi</i>	Natal Willow	E/D	Yes	Yes	Yes	Fast 900mm	Medium 2-5m	Stream banks	
<i>Schotia brachypetala</i>	Weeping Boer-bean	E/D	Moderate	Moderate	No	Medium 700mm	Large 8-12m	Open space, Parks	
<i>Schrebera alata</i>	Wild Jasmine	E	Moderate	Moderate	No	Medium 800mm	Medium 6-8m	Feature, Filler	
<i>Scolopia mundii</i>	Red Pear	E	Yes	Moderate	No	Slow 300mm	Medium 6-10m	Stream banks, Forest edge	
<i>Scolopia zeyheri</i>	Thorn Pear	E/D	Moderate	Moderate	No	Medium 500mm	Medium 3-10m	Screen, Hedge (barrier)	
<i>Syzygium cordatum</i>	Umdoni	Evergreen	No	No	Yes	Fast 1m	Medium 8-10m	Stream banks, Open space (moist areas)	Yes

Tarchonanthus camphorates	Camphor Bush	D/E	Yes	Yes	Yes	Medium 700mm	Medium 4-5m	Rehabilitation sites, Erosion control, Streams	
Trema orientalis	Pigeonwood	D/E	No	Moderate	No	Fast 1,5m	Medium 8-12m	Rehabilitation sites, Pioneer, Forest	
Vangueria infausta	Wild Medlar	D	Yes	Yes	No	Slow 300mm	Small 2-3m	Filler	Yes
Vepris lanceolata	White Ironwood	E	Moderate	Moderate	No	Medium 800mm	Medium 6-10m	Screen, Open space	
Xylothea kraussiana	African Dog-rose	E/D	No	No	No	Slow 300mm	Small 2-3m	Feature, Screen	
Zanthoxylum capense	Small Knobwood	D	Yes	Yes	No	Medium 700mm	Small 3-5m	Feature, Verge, Open space	
Ziziphus mucronata	Buffalo-thorn	D	Yes	Yes	No	Fast 1m	Medium 3-10m	Open space, Stream banks, Verge, Parks (hardy)	Yes

Appendix 7: Alien Vegetation Removal & Control Programme

1. RELEVANT LEGISLATION

NEMBA - Alien and Invasive Species Regulations - 1 August 2014

The Department of Environmental Affairs (DEA) manages Invasive Alien species (IAS) under the National Environmental Management: Biodiversity Act (NEMBA), Act 10 of 2004. This act aims to provide the framework, norms, and standards for the conservation, sustainable use, and equitable benefit-sharing of South Africa's biological resources.

The Alien and Invasive Species Regulations for this Act was published on 1 August 2014 and put into effect on 1 October 2014.

The main aim of this act is to ensure the preservation and integrity of ecological and biodiversity resources by:

1. Maintaining the production potential of land
2. Combating and preventing of erosion
3. Preventing the weakening or destruction of the water sources
4. Protecting the vegetation
5. Combating weeds and invader plants

2. REMOVAL METHODS

Department of Water Affairs

In keeping with these requirements, the Department of Water Affairs (DWA), in their Working for Water programme, recommends the following, regarding Invasive Alien species:

Any control programme for alien vegetation must include the following 3 phases:

1. Initial control: drastic reduction of existing population;
2. Follow-up control: control of seedlings, root suckers and coppice growth; and
3. Maintenance control: sustain low alien plant numbers with annual control.

The following is extracted from the Working for Water website (www.dwaf.gov.za/wfw/Control) and provides detail on species-specific methods to remove Invasive Alien species:

BUGWEED (SOLANUM MAURITIANUM)			
PLANTS	METHOD	PRODUCT	RATE
BIG TREES	CUT DOWN & SPRAY COPPICE	STARANE 200 (Fluroxypyr 200g/l)	125ml/10 litres water (0.5 litres/Ha – spray when 500mm tall)
		MAMBA (Glyphosphate 360g/l)	150ml/10 litres water (3 litres/Ha)
		TOUCH DOWN (Glyphosphate Trimesium 480g/l)	2 litres/Ha (spray when 500mm tall)
	CUT STUMP	CHOPPER (Imazapyr 100g/l)	200ml/10 litres/Ha (1 litre/Ha – cut surface only)
		TIMBREL 3A (Triclophyr Amine Salt 360g/l)	300ml/10 litres water (2.25 litres/Ha – cut surface only)
	FRILL	CHOPPER (Imazapyr 100g/l)	200ml/10 litres/Ha (1 litre/Ha)

		TIMBREL 3A (Triclophyr Amine Salt 360g/l)	300ml/10 litres water (1.5 litres/Ha)
GUMS TREES (EUCALYPTUS SP.)			
PLANTS	METHOD	PRODUCT	RATE
SEEDLINGS	Hand Pull	None	On observation
COPPICE*	Foliar Spray	BRUSH OFF (Metsulphfuron METHYL 500g/kg) plus MAMBA (Glyphosphate 360g/l)	200g/Ha (3 litres/Ha – apply to coppice 1.5 – 1.8m tall) 3 litres/Ha
FELLED TREES	Cut Stump	CHOPPER (Imazapyr 100g/l)	1250ml/10 litres water (6 litres/Ha) **
	Frill	CHOPPER (Imazapyr 100g/l)	1250ml/10 litres water (6 litres/Ha) **
Note : * Spot spray coppice: 16 litres water, 16g BRUSH OFF, 1% MAMBA, 0.5% ACTIPRON ** If species is known, check rate on product label.			
LANTANA (LANTANA CAMARA)			
PLANTS	METHOD		
SEEDLINGS	Hand pull or foliar spray with MANABA at 300ml/10l water or TOUCHDOWN at 6l/ha		
TREES	Foliar spray with TOUCHDOWN at 6l/ha or on cut stump apply CHOPPER at 200ml/10l water		
BIOCONTROL	The sap sucker <i>Falconia intermedia</i> . Contact Frist Heystech at ARC-PPRI Tel: (012)- 3293269		
SYRINGA (MELIA AZEDARACH)			
PLANTS	METHOD		
SEEDLINGS	Hand pulled or foliar spray using a herbicide with the active ingredient TRICLOPYR		
TREES	Must be cut down and stump treatment within 30 minutes using ACCESS and / or a IMAZYPR product.		
BIOCONTROL	Contact Frist Heystech at ARC-PPRI Tel: (012)- 3293269		
LONG-LEAVED WATTLE (ACACIA LONGIFOLIA)			
PLANTS	METHOD		
SEEDLINGS	Hand pull or foliar spray with GARLON 4 or VIROAXE at 60ml/10l water		
TREES	Cut down, wait for coppice and spray as above or on cut stump / frill apply TIMBREL 3A at 300ml/10l water		
BIOCONTROL	The seed weevil <i>melanterius ventrals</i> . Contact Fiona Impson at ARC-PPRI Tel: (012) 887 4690		
BLACK WATTLE (ACACIA MEARNsii)			
PLANTS	Methods		
SEEDLINGS	Hand pull or foliar spray with TOUCHDOWN at 3l/ha or foliar spray with GARLON 4 or VIROAXE at 25-75ml/10l water (Use at a lower rate for seedlings, higher rate for small trees)		
TREES	On cut stump/frill apply TIMBREL 3A at 300ml/10l water or treat with ECOPLUG (For inaccessible or dangerous areas)		
BIOCONTROL	The seed weevil <i>Melanterius ventralis</i> . Contact Fiona Impson at ARC-PPRI Tel: (012) 887 4690		
MAURITIUS THORN (CAESALPINIA DECAPETALA)			
PLANTS	METHOD		
SEEDLINGS	Foliar spray of GARLON 4 or VIROAXE at 50ml/10l water or MAMBA at 150ml/10l water.		
TREES	On cut stump/frill apply TIMBREL 3A at 300ml/10l water.		
BIOCONTROL	The seed weevil <i>Sulcobruchus subuturalis</i> . Contact Willem Coetzer at ARC-PPRI Tel: (012) 329 3269		

GREY POPLAR (<i>POPULUS X CANESCENS</i>)	
PLANTS	METHOD
SEEDLINGS	Foliar spray of GARLON 4 or VIROAXE at 50ml/10l water or cut stump and apply CHOPPER at 500ml/10l water
TREES	On cut stump/frill apply CHOPPER at 500ml/10l water (Poplar will always send up seedlings from suckers on the root, even if the tree is treated this way. This should feature in your planning)
PRICKLY PEAR (<i>Opuntia sp.</i>)	
METHOD	Inject into 2-4 premade holes per plant in 2ml doses: MSMA at 1l/1l water or MAMBA at 1l/2l water or TOUCHDOWN 330ml/10l water
CASTOR OIL PLANT (<i>Ricinus communis</i>)	
Method	On cut stump/frill apply CHOPPER at 3%
PEANUT BUTTER CASSIA (<i>SENNA DIDYMOBOTRYA</i>)	
METHOD	On cut stump/frill apply CHOPPER at 500ml/10l water
GUAVA (<i>PSIDIUM GUAJAVA</i>)	
METHOD	On cut stump/frill apply CHOPPER at 1250ml/10l water
BALLOON VINE (<i>CARDIOSPERMUM GRANDIFLORUM</i>)	
METHOD	No herbicide registered for this species. Foliar spray of 0.75% GARLON 4 could work
OLEANDER (<i>Nerium sp.</i>)	
METHOD	No herbicide registered for this species. 2% GARLON 4 with diesel on cut stump could work (Do not use any products of the plant – very poisonous)

If weeds or invader plants occur that are not indicated above, the land owner must control them by means of any of the control methods that are appropriate for the species concerned⁵⁴. Any action taken to control weeds or invader plants must be executed with caution and in a manner that will have minimal environmental impact.

RE-VEGETATION

Re-vegetation of previously disturbed areas i.e. areas cleared of alien species, should be undertaken using indigenous plant species (appendix 6). Sufficient time, irrigation rest periods and organic fertilisers should be applied to rehabilitated areas to promote establishment of plants.

ON-GOING MANAGEMENT

The following activities must be undertaken to ensure that on-going removal of alien vegetation from the site:

- Performance Indicators

Introduction of 'new' invasive species is prohibited and the spread of existing weeds must be minimised. Indigenous plant species are to be assessed for their successful establishment.

- Monitoring And Reporting: Visual Site Assessment

⁵⁴ This must be done in consultation with the Msunduzi Municipalities Environmental Management Unit

This is to be done initially by the Contractor with the Msunduzi Environmental Management Unit present, during the construction phase of the project. Thereafter (during operational phase) the site is to be assessed in terms of all invasive plant species.

- **Corrective Action**

Education of construction and operational personnel with regards to spread and maintenance of alien plants is required. On-going implementation of alien plant removal methods is to be done, as described above followed by re-vegetation using indigenous species.

Appendix 8: Generic Rehabilitation Plan

Introduction

Rehabilitation is defined as the return of a disturbed area to a state which approximates the state that it was prior to disruption and construction activities. It is an important process whereby vegetation once disturbed can return to functionality within an area, ultimately conserving, preserving and producing ecosystem goods and services. The purpose of this plan is aimed at Post-Construction rehabilitation of any development site within the Msunduzi Municipal area.

In terms of the National Environmental Management Act (NEMA) 107 of 1998, Section 28 everyone is required to take reasonable measures to ensure that they do not contaminate the environment. Reasonable measures include informing and educating employees about environmental risks of their work and training them to operate in an environmentally responsible manner. Further; in terms of NEMA, the cost to repair any environmental damage shall be borne by the person responsible for the damage.

If there is effective Environmental Management in place it is expected that most negative environmental impacts, associated with development projects within Msunduzi Municipal areas can be mitigated. A person designated to implement the Generic EMPr will need to regularly monitor the site to ensure that the required environmental controls are in place and working effectively.

Storm water

Ensure that in the long term; storm water is protected from contamination by potential pollutants. Refer to appendix 9 for storm water outlet and bedding specifications.

Waste and Spillages

- All spillages must be cleaned and contaminated soil & or water must be removed and disposed of appropriately.
- All remaining waste bins and/ or skips must be removed and disposed of. Records of disposal must be retained. As far as possible Material like Plastic, paper, cardboard must be recycled.
- All excess concrete must be removed from the site on completion of works and disposed of. Burying or washing of the excess into the ground is not permitted.
- No waste must be buried or burnt on site. All waste is to be transferred to an appropriate and permitted disposal facility. Proof of disposal must be retained and provided on request.
- All excess aggregate is to be removed.
- Used oil must be collected by a registered used oil contractor and documentation to this effect provided.
- Surfaces are to be checked for waste product from activities such as concreting or asphaltting and cleared in a manner approved by the appointed person.
- No litter must be left on site.

Erosion Control: Slopes, Cuttings and Access Roads Final Shaping

1. Ensure that all access roads utilised during construction (which are not earmarked for closure and rehabilitation) are returned to a usable state and / or a state no worse than prior to construction. All

temporary access roads should be ripped and rehabilitated with topsoil and re-vegetated and soil must be put back in the order it was removed. Sub soil mustn't be mixed with top soil.

2. Backfill all prospecting boreholes, excavations, cuttings and test pits with insitu material.
3. Slopes must be shaped for stabilization, prior to top soil placement and re-vegetation and / or seeding.
4. In general, no slopes steeper than 1(V):3(H) are permitted, unless otherwise specified by the Msunduzi Municipality and Environmental Management Unit. Steeper slopes will require extra protection and erosion control systems.
5. Programme the backfill of excavations so that subsoil is deposited first, followed by the topsoil.
6. Deficiency of backfill may not be made up by excavating haphazardly within the Work Site. Additional fill may only be imported from approved borrow areas as indicated by the Msunduzi Municipality Environmental Management Unit.
7. Monitor backfilled areas for subsidence (as the backfill settles) and fill depressions using available material.
8. Dismantle and flatten temporary drifts and river crossings, reinstating all drainage lines to approximate their original profile.
9. Shape all disturbed areas to blend in with the surrounding landscape as best as possible.
10. Ensure that no excavated material or stockpiles are left on site and that all material remaining after backfill is smoothed over to blend in with the surrounding landscape or removed to an approved site.

Topsoil Replacement and Soil Amelioration

1. The principle of Progressive Reinstatement must be followed wherever possible. This includes the reinstatement of disturbed areas on an on-going basis, immediately after the specified construction activities for that area are concluded.
2. Execute top soiling activity prior to the rainy season or any expected wet weather conditions.
3. Avoid working with soil stockpiles during wet weather to prevent unnecessary compaction.
4. Replace and redistribute stockpiled topsoil together with herbaceous vegetation, overlying grass and other fine organic matter in all disturbed areas of the construction site, including temporary access routes and roads. Replace topsoil to the original depth (i.e. as much as was removed prior to construction).
5. Place topsoil in the same area from where it was stripped. If there is insufficient topsoil available from a particular soil zone to produce the minimum specified depth, topsoil of similar quality may be brought from other areas of similar quality.
6. If possible avoid using soil suspected of being contaminated with the seed of alien vegetation.
7. Shape any remaining stockpiled topsoil not utilised elsewhere in an acceptable manner so as to blend in with the local surrounding area.

8. Any erosion damage caused during construction must be repaired. The affected area must be ripped, reshaped and soil replaced. The eroded area must be re-vegetated or measures put in place to control further erosion.

Maintenance

1. Allow for a maintenance period of one year following practical completion unless otherwise specified in Defects liability period.
2. Landscape maintenance is to be undertaken by suitably qualified persons, making use of the appropriate equipment.
3. Cordon off areas that are under rehabilitation as no-go areas using danger tape and droppers. If necessary, these areas should be fenced off to prevent vehicular, pedestrian and livestock access.
4. Where hydroseeding is carried out, the commencement of watering may be postponed until a more favourable time of the year.
5. Watering must, however, commence and continue immediately after the seeds have germinated and growth begins.
6. For planted areas that have failed to establish, replace plants with the same species as originally specified.
7. A minimum grass cover of 80% is required, and individual plants must be fully established at the end of the Maintenance Period.
8. In the case of sodding, acceptable cover entails that 100% cover is attained by the specified vegetation.
9. Bare areas that show no specified vegetation growth three months after rehabilitation are to be spread with additional topsoil, ripped to a depth of 100mm and re-planted, re-sodded, re-hand sown or re-hydroseeded.

Re-Vegetation

Re-vegetation of previously disturbed areas, i.e. areas cleared of alien species, to be rehabilitated using indigenous species. Sufficient time, irrigation, rest periods and organic fertilisers should be applied to rehabilitated areas to promote establishment of plants.

In planting of vegetation:

1. All planting work is to be undertaken by a suitably qualified Contractor.
2. Make use of mobile plant and equipment which is appropriate to the task (i.e. for both rehabilitation and maintenance) in order to minimise the impact on and extent of damage to the environment.
3. Planting should preferably be done during the rainy season.
4. Unless otherwise specified by Msunduzi Municipality and the appointed person, excavate square holes of 800mm x 800mm x 800mm on average for trees and 500mm x 500mm x 500mm on average for shrubs that have to be replanted.

5. As much of the soil as possible must be retained around the roots of the plants during planting. The plant must be planted into the specified hole size with the approved soil, compost and fertiliser mix used to refill the plant hole and must cover all the roots and be well firmed down to a level equal to that of the surrounding in situ material.

6. After planting, each plant must be well watered, adding more soil upon settlement if necessary.

7. Stake all trees using three weather resistant wooden stakes anchored firmly into the ground. Two of the three stakes are to be located on the windward side of the plant. Galvanised wire binding, 3mm thick, covered with a 20mm diameter plastic hosepipe must be tied tightly to the stakes, half to two thirds the height of the tree above the ground and looped around the trunk of the tree.

8. Place stakes at least 500mm apart and away from the stem and roots of the tree, so as not to damage the tree or its roots. This distance will depend upon the size of the tree planted.

9. Remove stakes and wire binds over time as required, as plants become established.

10. Where necessary, protect newly planted trees against wind, frost and wild animals by means of fencing, sacking or frost nets.

11. Thoroughly water plants as required until the plants are able to survive independently.

12. A raised circular 200mm high subsoil berm, placed 500mm (shrubs) to 750mm (trees) from the plant's stem must be provided for the watering. Do not simply leave the excavated plant hole partially backfilled for this purpose – the berm must be raised above the natural soil level.

Seeds and Seedlings

14. All planting work is to be undertaken by a suitably qualified Contractor, making use of the appropriate equipment.

15. An alternative to harvesting seeds and germinating these is to uproot small seedlings between 40mm to 100mm high from an area of mature forest undergrowth where there are many. Best results are obtained immediately after heavy rain. The suitable qualified contractor must do the work with approval.

16. Tree seedling material should be fresh and of local origin. Avoid using plants from far afield as they may not be best suited to local climatic or soil conditions.

17. Small seedlings are likely to transplant more successfully than large ones. These should be potted and kept under nursery conditions until they are large enough to plant out.

Grassing

18. Grassing must be undertaken by a suitably qualified Contractor, making use of the appropriate equipment.

19. If rehabilitation is undertaken in autumn & winter then hand seeding and or hydroseeding must be undertaken with a winter grass seed mix.

20. The grass seed mix must be discussed with Environmental Management Unit and plant species for rehab purposes can be taken from appendix 6 of the EMPr.

1) Hand seeding

1. All seed supplied should be labelled in accordance with the Government Seed Act (Act No. 20 of 1961).
2. The soil should be loose and uniformly wet to a depth specified by Msunduzi Municipality and or appointed person, before any seeding commences.
3. Halve the seed and fertiliser mixture as specified and apply evenly in two immediate successive applications perpendicular to each other.
4. The seeded area must be raked over after seed application and well watered.
5. Irrigate as required until the grass is able to survive independently.

2) Hydroseeding

1. Hydroseeding entails adding a specified seed mix to slurry containing water and other approved materials to enhance plant growth potential. This mixture is applied by means of a spraying device onto the prepared ground areas to be seeded.
2. All seed supplied should be labelled in accordance with the Government Seed Act (Act No. 20 of 1961).
3. The soil should be loose and uniformly wet to a depth specified by Msunduzi Municipality and or appointed person, before any seeding commences.
4. Add the specified seed mix and necessary fertiliser to the required amount of water and apply using an approved hydroseeding machine.
5. Unless otherwise specified, the rate of application of the slurry will not be less than 30 cubic metres per hectare and will be applied in such a manner as to ensure even distribution of seed and fertiliser throughout.
6. Where possible, keep the seedbed moist after hydroseeding, to ensure good germination.
7. Irrigate as required until the grass is able to survive independently.
8. Follow up Hydroseeding should occur in areas where seeds have not established.
9. Maintenance period

Alien Vegetation Removal and Rehabilitation Plan

Alien vegetation must be monitored and removed on an on-going basis specified in Defects liability period by developer/ Contractor. Indigenous vegetation planting must continue on an on-going basis if it is required during the Defect/Liability Period.

Natural ecosystems which have not been disturbed by human influence are less susceptible to encroachment. However, if natural vegetation is disturbed, alien plants are often able to gain a foothold. Some alien plants are able to out-compete indigenous vegetation due to the absence of natural control mechanisms, such as pathogens, insects or herbivores. These alien species succeed at the expense of indigenous species and are referred to as Invasive Alien Plants. This can lead to mono-dominance by the invader at the expense of the indigenous plant, animal or insect communities.

Alien plants were introduced into South Africa:

- As decorative plants (e.g. Jacaranda, Lantana),
- As sources of food (e.g. guava),
- As for the timber industry (e.g. gum, wattle and pine) or
- Unintentionally, often in fodder or animal bedding material.

Thus to plan an effective alien plant control program it is necessary to understand why certain alien plant species have established so successfully in South Africa. Controlling alien vegetation is a costly exercise which requires planning and preparation prior to any fieldwork. Planning, implementation and results will differ depending on what the program is designed to achieve. This may be to satisfy water conservation issues or to conserve biological diversity.

Thus before initiating an alien plant control program: It is essential to have a long-term strategy in place, combined with a vision of what plant community is to replace the alien plants. If such a strategy is not in place, then the alien plant control program is highly likely to fail. A suite of characteristics, such as prolific seed dispersal, rapid growth rates and easy germination, characterise alien invasive plants. Consequently, areas cleared of alien plants are most likely to be replaced by the same species or by other invasive plants with similar characteristics unless an alternative vegetation type is encouraged. Follow-up operations to control invasive seedlings are critical.

Newly cleared areas can be susceptible to erosion and appropriate rehabilitative steps such as re-seeding with indigenous grasses and minor soil retention structures are essential. Thus a biological knowledge of the region is critical to predict what vegetation will replace the cleared alien vegetation. As mentioned above clearing is costly and therefore there should be adequate funds allocated for long term operation until the land is fully rehabilitated. It is the developer's responsibility to ensure that there are adequate funds, rehabilitation program in place and an appropriate system to manage the follow-ups. For more details on alien species removal & control methods refer on Appendix 7.

The rehabilitation of areas densely infested with alien plants can be expensive. Thus it is better to treat areas of light infestation first, as there is usually some grass cover which will take over from the alien plants once the control program is initiated. A dense infestation of alien plants generally remains stable and is best left alone until sufficient resources are available to deal with this infestation properly.

On-Going Management

The following activity must be undertaken to ensure the on-going removal of alien vegetation from the site:

- Performance Indicators: Introduction of ‘new’ invasive species must be prohibited and the spread of existing weeds must be minimised. Indigenous plant species must be assessed for their successful establishment.
- Monitoring and Reporting: Visual site assessment. This is to be done initially by the contractor during the construction phase, thereafter by the Property Owner / applicant during operation. The initial clearing must start immediately after post construction activity, and the follow up site monitoring in terms of invasive plants to be done accordingly with the defect liability period.
 - Any control programme for alien vegetation must include the following 3 phases:
 1. Initial control: drastic reduction of existing population;
 2. Follow-up control: control of seedlings, root suckers and coppice growth; and
 3. Maintenance control: sustain low alien plant numbers with annual control. Refer on (Appendix 7).
- Corrective Action: Education of construction and residents with regard to spread and maintenance of alien plants. On-going implementation of alien plant removal methods is to be done, followed up with re-vegetation using indigenous species. Refer on (Appendix 6) for indigenous plants list and (Appendix 7) for alien plants removal and control programme.

Conclusion

Under the guidance of the Msunduzi Municipality Environmental Management Unit, this Rehabilitation Plan will serve to guide the remediation process and monitor the Contractor’s effectiveness in implementing it. The Msunduzi Municipality Environmental Management Unit recommends that a site audit takes places once the remediation work is completed to assess whether this Rehabilitation Plan and all the above mentioned mitigation measures were effectively implemented. Should there be outstanding issues in this rehabilitation plan the developer/ land owner will be held liable and be responsible for ensuring that measures are adequately implemented

Appendix 9: Storm Water Outlet & Bedding Specifications⁵⁵

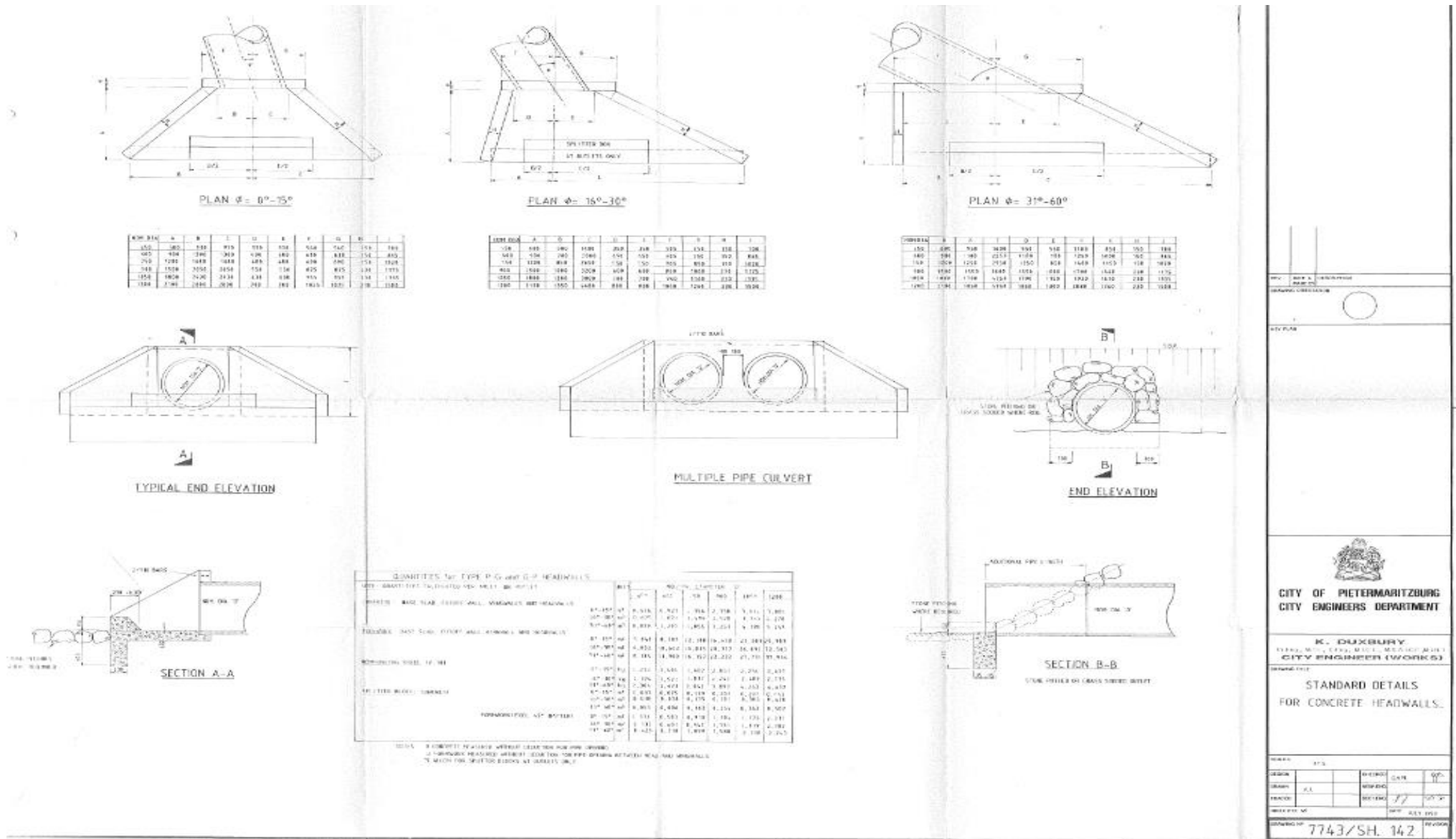

⁵⁵ Diagrams obtained from Msunduzi Municipalities Storm water and drainage unit

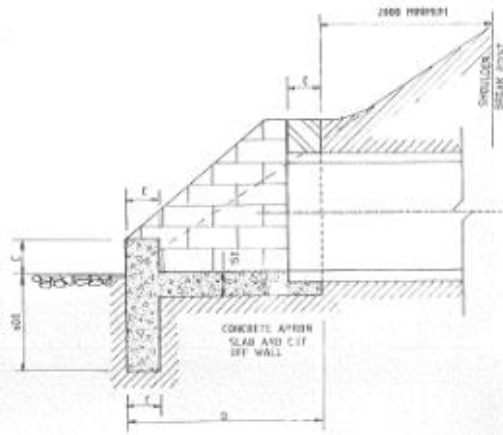

SECTION A-A

NOZZLE DIAMETER	DIMENSIONS					
	A	B	C	D	E	F
100	600	230	250	940	1650	2880
150	750	230	440	1150	2080	
200	900	230	1170	1380	2640	
250	1050	230	1400	1650	3100	
300	1200	230	1640	1830	3700	
350	1350	230	1870	2050	4350	
400	1500	230	2100	2270	5000	

OUTER DIAMETER OF PIPE 150

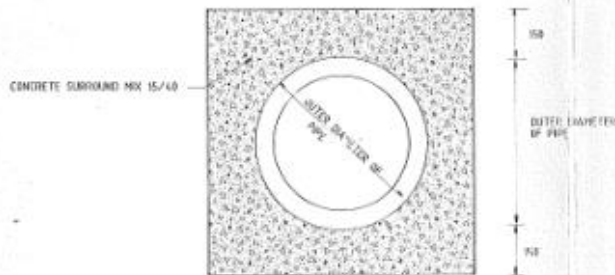

DETAIL OF CONCRETE ENCASED PIPE

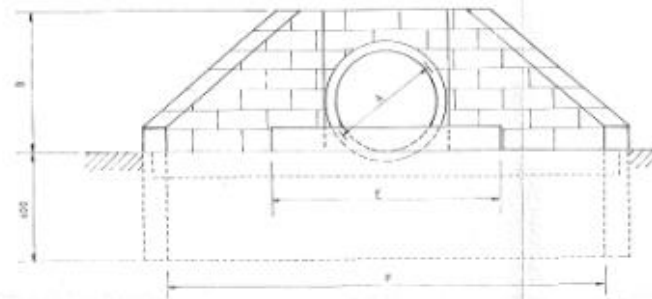

FRONT ELEVATION

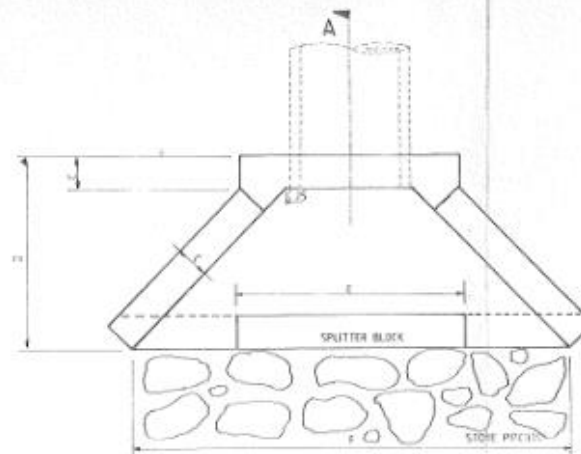

PLAN

NOTE

1. SPLITTER BLOCK AND PITCHING TO BE PROVIDED AT ALL OUTLETS WHERE EROSION LIKELY TO OCCUR. IT IS NOT REQUIRED AT INLETS.
2. SPLITTER BLOCK MAY BE OMITTED IF DISCHARGE VELOCITY IS LESS THAN 0.9 M/S.
3. CUT OFF WALLS MAY BE OMITTED IF STRUCTURE IS FORGED OR RICE.
4. PIPES TO BE FLUSH WITH HEADWALL.
5. ALL CONCRETE TO BE 15MPA.
6. ALL HEADWALLS TO BE CONSTRUCTED OF 230MM BRICKWORK, UNLESS IT IS SUITABLE TO USE CONCRETE. DIMENSION 'C' WILL HAVE TO BE ADJUSTED AS FOLLOWS:
FOR 300MM TO 350MM, DIMENSION 'C' = 150MM
FOR 400MM TO 500MM, DIMENSION 'C' = 230MM

LEGEND

—	BOUNDARY
—	EXISTING WATER MAINS
—	EXISTING SEWERS
—	EXISTING STORMWATER
—	ELECTRICITY
—	G.P. PIPES AND CABLES
—	PROPOSED WATER MAIN
—	PROPOSED SEWERS
—	PROPOSED STORMWATER

REV.	DATE	DESCRIPTION



CITY OF PIETERMARITZBURG
CITY ENGINEERS DEPARTMENT

K. DUXBURY
Pr. Eng., M.Sc., C.Eng., M.I.C.E., M.S.A.L.C.E. (M.I.)
CITY ENGINEER (WORKS)

DRAWING TITLE

STANDARD DETAILS FOR
BRICK HEADWALLS

SCALE

N.T.S.

DESIGN	CHECKED	DATE	APP.

INDEX REF. NO. DATE 01/1/1995

DRAWING NO. 7743/SH.143

a. RIGID PIPE ON CLASS A BED

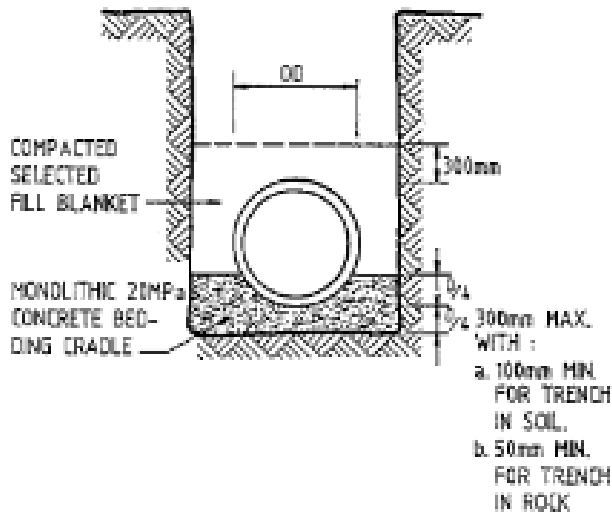

b. RIGID PIPE ON CLASS B BED

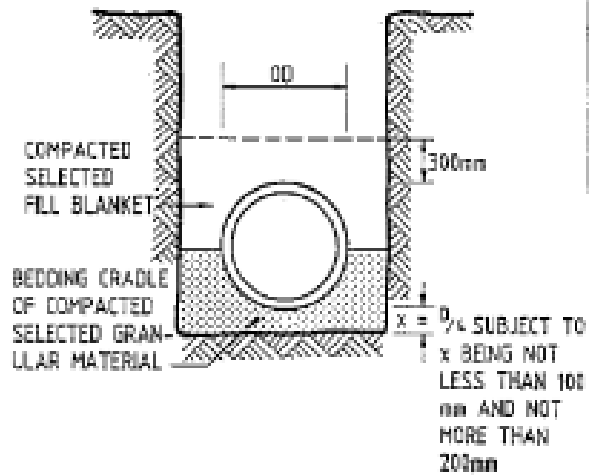

c. RIGID PIPE ON CLASS C BED

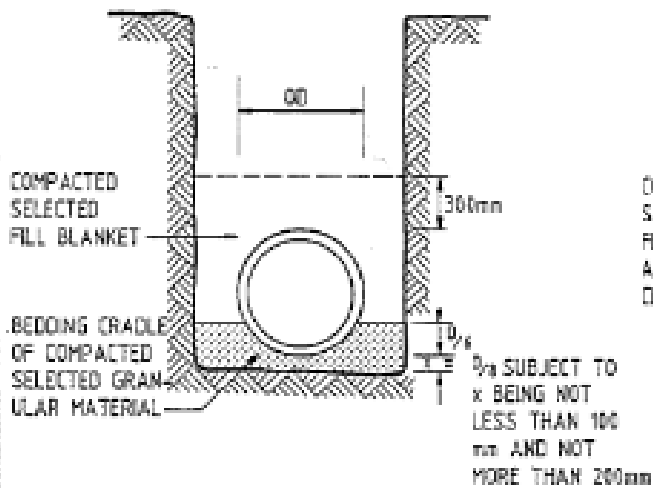

d. RIGID PIPE ON CLASS D BED

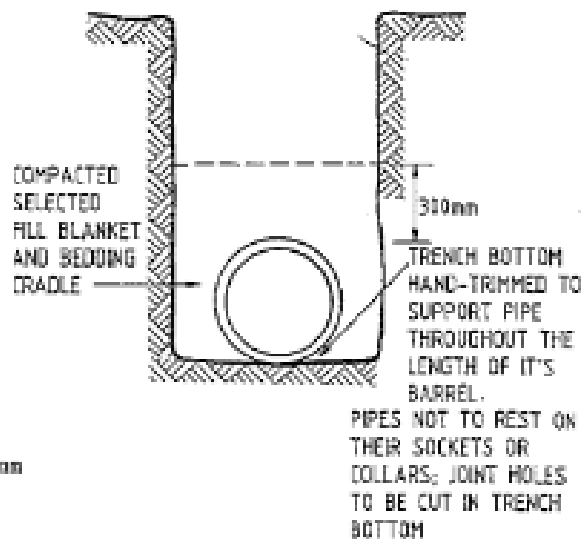

1	REDRAWN TO SABS STANDARD	I.C.A.	NOV. 1991		
No. Nr.	Revisions Wysigings	By Deur	Date Datum	Eng. No. Tek. Nr.	Reference Dops. Verwysings Tok.

- STANDARD DRAWING -
STORMWATER PIPE BEDDING DETAILS
 (SABS 1200 LB)

Scale Skale	NOT TO SCALE				Index Ref. No. Indeks Verw. Nr.
Drawn Geteken	I.C.A.	SA.	Traced Nagetrek	J.H.M.	Checked Getoets
Sect. Eng. RID. Ing.	A.C.E. A.S.	D.C.E. A.D.S.	City Engineer Stadsingenieur		Drawing No. Tekening Nr.
			J.B. ROBBINS P. Eng. CIVIL & SURV. CITY ENGINEER		Rev. No. Her. Nr.
					7743
					1

SHEET 106

Appendix 10: Waste Management Plan

Suggested guidelines & protocols

By encouraging reuse, recycling and resource recovery in operational activities, there can be a noticeable reduction in the amount of waste that ends up in landfill. Reducing waste generated can result in money being saved, and benefit the environment.

The intention of this Waste Management Plan is to ensure that various procedures and codes of good practice are outlined to ensure that an environmentally friendly practice is adopted. A number of different waste streams will be looked at. This plan also makes recommendations for the minimisation, reuse and recycling of waste, as well as its final disposal. All subcontractors are required to identify, maintain proper control and provide documentation for the disposal of materials described in this plan.

Waste Sources:

Solid waste will be generated by a number of different sources. These sources include but are not limited to the following:

1. Administrative offices
2. Ablutions
3. Office facilities
4. Bins at various points of the facility
5. Take out containers etc.

Solid Waste Types:

Numerous different waste types will be generated by various sources. These wastes include but are not limited to the following:

1. Food packing – paper, plastic, tin, glass, polystyrene
2. Card board – boxes
3. Packing materials – bubble wrap, Styrofoam and polystyrene
4. General domestic litter – i.e. food and beverage packaging
5. Office waste- paper, plastic, printer cartridges, newspaper
6. Cleaning materials – spills and packaging
7. Bathroom waste – paper towels and sanitary waste
8. General maintenance waste – light bulbs

Storage Management & Handling of Waste on Site:

All solid waste is to be stored in water tight, scavenger-proof and wind proof waste receptacles in a designated storage area which is fenced and access controlled.

The bins located within the facility should be lined with appropriately sized plastic bags. The bins located outside must have lids to prevent litter from becoming wind-blown. These bins should be regularly emptied to prevent overflow. The plastic lining should be immediately replaced. Waste collected from these bins on the property should be immediately transferred to the above mentioned designed waste areas located on the property to await collection by the relevant service provider.

Recyclable waste, i.e. paper, plastic, glass, tin, polystyrene etc. should be separated at source. The separated waste should then be transported to separate waste receptacles in the designated central waste storage area to await collection and recycling.

Fluorescent and Compact Fluorescent light bulbs (CFL's or energy saving light bulbs) must be stored in a separate area and carefully handled in order to ensure that none of the bulbs break

before they can be appropriately disposed of. A separate area should be designated for the storage of these bulbs.

Printer cartridges should be stored separately from other general waste and recycled.

Waste foods which are inedible should either be disposed of with waste which is designated for disposal at a registered land fill site or should be composted.

Disposal of waste:

The following is recommended regarding the disposal of solid waste generated on site:

1. The service provider must be responsible for the safe removal, transport and disposal of solid waste produced on the site to a registered Landfill Site.
2. Recyclable waste should be transported to the nearest recycling depot.
3. Fluorescent and CFL light bulbs should be transported to the nearest H:h (low hazardous landfill site) landfill site for appropriate disposal.
4. It is recommended that the waste printer cartridges generated be collected and recycled by appropriate local companies.
5. It is recommended that all cleaning materials which are utilised by the cleaning staff be biodegradable. Spills and packaging materials can then be disposed of at a landfill site.

Recommendation for waste minimisation, re-use and recycling:

Waste minimisation refers to methods of reducing waste at the source. In general the means practicing the following:

1. Reusing (or promoting the reuse of), materials in their original forms as far as possible.
2. Separating waste into different waste courses at source, before it is collected for recovery and recycling purposes.
3. Diverting waste from landfills through appropriate mechanisms and facilities.
4. Facilitating the processing or treatment of any recyclable waste, in an economical and environmentally sustainable manner.

There are a number of practices which could be implemented to reuse and recycle solid waste and thus minimise the amount of solid waste produced by the development / activity. These include:

1. Donate boxes and polystyrene packing materials to local schools and/or orphanages for children to use in art projects.
2. Recycle paper, plastic, glass and tins where possible (identify companies that offer recycling initiatives and compensation).
3. Recycle printer cartridges and all light bulbs.

Conclusion:

If these measures and recommendations are implemented on the site, there will be a significant minimisation of waste. It is recommended that this Waste Management Plan be complied with as far as reasonably possible.

Name of Manager / Supervisor

Signature

Date

Appendix 11: Spill Contingency Plan

Site map of the location must be attached to this document. This map is intended to illustrate the facilities relationship to other areas that may be affected by the spill.

1. Name, address and Job Title of the owner / person in charge i.e. Manager / Supervisor				
Name	Address	Contact number	Job title	
2. Name, 24 hour telephone number and Job Title for person/s responsible for activating the spill contingency plan				
Name	Address	Contact number	Alternate contact number	Job title
3. Should the main person/s not be accessible, an alternative person must be identified				
Name	Address	Contact number	Alternate contact number	Job title
4. A description of the property / facility, including location, size and storage capacity				
Description of facility:				
5. A description of the type and amount of contaminates usually stored at the location.				
Description of contaminates:				

6. Steps to be taken to report, contain, clean-up and dispose of contaminates in the case of a spill. Reporting is the notification of all parties involved. This can include internal as well as external reporting procedures. A description of a public reporting procedure used to alert anyone who may be affected by the spill is required.
Reporting:
7. Clean-up is the removal of the contaminant from the environment. This should consider the possible scenarios or spill incidents that could occur at the facility including a worst case scenario.
Clean-up:
8. Disposal is the treatment of the contaminant such that it is no longer a threat to the environment. Contingency plans must contain appropriate disposal procedures for the materials stored at the facility.
Disposal:
9. The means by which the spill contingency plan is activated (i.e. procedures to activate appropriate response equipment and personnel)
Activation of spill contingency plan

10. A description of the training provide to employees to respond to a spill. A sound training program is necessary when dealing with an emergency situation. This program should include knowledge and the use of any response equipment

Description of training program:

11. An inventory of and the location of response and clean-up equipment available to implement the spill contingency plan

Inventory and location of responses and clean up equipment:

List of emergency numbers	Numbers	Alternate numbers
Fire	0800 033 911	033 845 5911
Police	10 111	
Ambulance	10 177	
Electricity	0800 332 120	0860 204 560
Water	0800 001 868	

Date of contingency plan implementation	
--	--

Clean up specialists to assist in responding to spills	Spill assistance list	Signature of property owner / applicant / developer

Name of Land Owner

Signature of Land Owner

Date

Appendix 12: Non-Compliances with EMPr

DETAILS OF NON-COMPLIANCE	SEVERITY RATING Low/Medium/ High	REQUIRED CORRECTIVE ACTION	PROPOSED CLOSE OUT DATE	RESPONSIBLE PERSON	COMPLETION DATE

Appendix 13: Environmental Awareness Training

For effective implementation of the EMPr, it is important to communicate environmental awareness at all levels within an organisation. This ultimately ensures that there is a good understanding and knowledge bases for environmental awareness and environmental related incidents.

1. **CONDITIONS:**

- 1.1. Environmental awareness training is required in order to ensure compliance with EMPr and Environmental Authorisation⁵⁶ conditions / actions. It ensures that environmental degradation is reduce by ensuring that all staff, workers, contractors, subcontractors, engineers and all other parties involved in the project / development are made aware of the conditions on site and the EMPr has been made available to them⁵⁷.
- 1.2. The Land Owner, Engineer and Contractor must sign Appendix 15 of the EMPr. This document serves as a record that the EMPr has been received by the aforementioned parties and that the EMPr and conditions have been accepted.

2. **INSTRUCTIONS FOR THE TRAINER:**

- This can be conducted by the Contractor and / or Engineer (alternatively the Msunduzi Municipality's Environmental Compliance Monitoring & Enforcement personnel can be contacted for assistance in this matter)

2.1. **Setting Up**

- A date and time must be set for environmental awareness training to be conducted prior to the commencement of site works / clearing. The land owner / applicant, engineer and contractor must be present at the aforementioned training session.
- The training session must be conducted at the site to ensure that workers / staff and all parties involved in the project are aware of the area and sensitive areas / features can be pointed to be staff.
- Ensure that copies of the Environmental Code of Conduct⁵⁸ and printed and placed around main areas to ensure that staff is aware of the document.
- Check what is the common language spoken by staff workers, if translators are required this must be arranged prior to the meeting taking place.

3. **Environmental Awareness Training**

The following information / items must be discussed with all staff at the Environmental Awareness Training

- 3.1. An EMPr has been included in the contract for this project and thus all conditions must be implemented and adhered to by all parties involved in the project / development. The EMPr aims at ensuring that the environmental in protected during construction activities.
- 3.2. The purpose of this awareness training is to ensure that staff are familiarized with the contents of the EMPr and are aware of the conditions for preventing environmental degradation.

3.3. **What Is the Environment?**

The environment is something you are very familiar with. It's everything that makes up our surroundings and affects our ability to live on the earth—the air we breathe the water that covers most of the earth's surface, the plants and animals around us, and much more. The environment comprises of living and non-living things (buildings, cars, houses etc.). An important factor to include is that all people and their needs are an important factor of the environment and the need to promote sustainability.

⁵⁶ If applicable

⁵⁷ Ensure that all parties involved in the project / development are provided with a copy of Appendix 15 of the EMPr

⁵⁸ Appendix 1 of the EMPr

(Implement a group discussion and ensure that all staff members are actively involved in the discussion)

3.4. Reasons for conserving and protecting the environment

The environment provides resources for us all, i.e. food, water, air etc. if the environment is damaged it cannot provide us with these resources, this will affect us all and future generations.

The Constitution of the Republic of South Africa, Act 108 of 1996 (Section 24) states that all citizens have the right to a safe and healthy environment. It also provides the right for the benefit of present and future generations to an environment that is protected from pollution and degradation through reasonable legislation and other measures. Therefore if the environment is harmed in any way, there will be consequences for other people, denying them the right to a healthy environment.

Examples must be used here i.e. if oil / paint etc. is thrown into a river, this negatively impacts the people downstream that depend on the river as a source of water for drinking washing clothes cooking etc.

If the environment is damaged / harmed during construction activities, the following will occur:

- The company / contractor / engineer may be liable for fines in terms of the Msunduzi Municipality Environmental management bylaws
- Depending on the severity of the damage and the extent of the environment which is degraded, all site works may be asked to stop and the DEDTEA may be requested to become involved.

3.5. How the following activities can impact the environment

- *Ablution facilities:* must be used to ensure disease and germs are not spread. These facilities are provided by the contractor and MUST be used. If any staff members are found defecating in the areas surrounding the construction site, with contractor may be liable for a fine and if persons are caught they will be asked to leave the site. The EMPr contains specific actions relating to this and the contractor must ensure that these are discussed with staff.
- *Dealing with hazardous materials:* correct protective gear MUST be used by all staff dealing with chemicals and hazardous material to ensure that they are protected from injury (A.5.3 of the EMPr – Page 22). If correct protective gear is not used, this could lead to severe illnesses / injuries and in extreme cases even death.
- *Correct procedures for removal of spills:* when chemicals are spilt on to the ground they contaminate soil and can reach rivers and water bodies. This leads to water becoming dangerous due to chemical contents and can lead to illnesses in animals and humans. It is essential that all spills are reported to the contractor / engineer and the correct procedures are followed to ensure that they are appropriately cleaned up and contaminated material is disposed of⁵⁹. Contractors will have spill kits ready for use in emergencies and must be followed.
- *Mixing cement / paint / other chemicals on soil / grasses surfaces:* this damages the soils and harms the environment as the chemicals are absorbed into the ground. Nothing will grow in these areas and this could lead to erosion occurring. Please ensure that impermeable boards are used should mixing be required⁶⁰ or alternatively, impermeable areas for mixing should be assigned.
- *Proper handling of waste material:* bins are provided around the site and these MUST be used. Recycling provides jobs and helps keep the environment clean. All staff must be responsible for cleaning up of the site and areas affected by construction activities.
- *Washing of vehicles and machinery:* vehicles must not be washed on site as this leads to soil and ground water becoming polluted. This means that people using water downstream will be affected by the quality of water they are using.

3.6. Staff conduct

The contractor must ensure that all staff is made aware of the follow:

- Appropriate safety gear must be worn on the site and during construction activities
- Eating areas must be appropriately marked and demarcated

⁵⁹ Appendix 14 of the EMPr: Spill protocol

⁶⁰ These must be provided by the contractor

- All complaints must be directed to the Contractor / Engineer and must be entered in the Complaints Register⁶¹
- Staff / workers must remain within the boundaries and areas demarcated for construction activities. Under no circumstances should site works or activities infringe within sensitive areas i.e. wetlands / rivers / streams / drainage lines etc.
- All mixing of materials such as concrete / paint etc. must take place of impermeable surfaces provided by the contractor
- Spill kit instructions and spill protocols⁶² provided in the EMPr must be adhered to in the event of a spill occurring.
- Bins and / or skips must be used for litter. Under no circumstance should waste be burnt or buried.
- Should artefacts be discovered the contractor must immediately cease site works and ensure that AMAFA are contacted. The area surrounding the artefact is not to be disturbed.
- Areas must not be cleared unnecessarily. Should staff require assistance in identifying site boundaries, the engineer and contractor must ensure that aforementioned areas are demarked with danger tape / chalk.
- Under no circumstances should alcohol, drugs, weapons (guns, knives etc.) be brought onto the site.
- Lists of emergency numbers must be printed and made available at strategic locations around the site should there be an emergency.
- Should any animals be found on site, please ensure that the contractor and engineer are notified and that relevant authorities are contacted i.e. the SPCA, Ezemvelo KZN Wildlife etc.

3.7. Reporting issues of concern

- Should there be any issues of concern noticed by staff, the foreman / supervisor must be notified immediately to ensure that the correct measures are followed to rectify the problem

List of emergency numbers	Numbers	Alternate numbers
Fire	0800 033 911	033 845 5911
Police	10 111	
Ambulance	10 177	
Electricity	0800 332 120	0860 204 560
Water	0800 001 868	
Foreman		
Contractor		
Engineer		
Land owner		

⁶¹ Appendix 2 of the EMPr

⁶² Appendix 14 of the EMPr

Accepted and signed by

----- Name	----- Designation	----- Company	----- Contact number	----- Signature	----- Date
----- Name	----- Designation	----- Company	----- Contact number	----- Signature	----- Date
----- Name	----- Designation	----- Company	----- Contact number	----- Signature	----- Date

Signing this document serves to confirm that all necessary parties involved in the project / development have received the Environmental Awareness Training and that conditions and activities contained in the EMPr have been discussed with all relevant personnel.

Appendix 14: Response Protocol for River Pollution Incidents within Umgungundlovu District Municipality⁶³

1. Introduction.

- a. The purpose of this document is to improve response in addressing spill incidents that are affecting the quality of water resources and human health. Pollution incidents in streams and rivers are many and varied. Furthermore the pollution in a stream or river might not be as a result of direct disposal of hazardous materials into a water course, but rather as the consequence of a land based spill which is caused by an incident which has occurred some distance from the water course, but is washed into a water course by rain or by the clean-up process or even infiltrate the ground and pollute underground water sources.
- b. The cleaning up of any hazardous pollution incident is expensive and can be a lengthy process. The challenges regarding clean-ups and rehabilitation includes financial provision and identifying a responsible person.
- c. Time is of the essence and someone has to initiate the call to appoint a company and is then deemed to be responsible for settling the account. In the event where the culprit is known, they pay for the clean-up. However the culprit is not always known and the account would have to be settled by the Msunduzi Municipality.
- d. It then has to be determined who has the responsibility for initiating the callout process notwithstanding the financial consequences.

2. Rationale

The sooner a spill is addressed the less likely the consequences. Therefore someone has to make the call to appoint a clean-up company.

The notification of a spill incident can come from several sources:-

- Member of public reporting to the Fire and Emergency services control room.
- An SAPF member attending the incident reporting to the Fire and Emergency Services control room.
- The Msunduzi Municipality Department of Environmental Health receiving notification of such an incident.
- Disaster Management Unit reporting to the Fire and Emergency Services control room.
- Umgeni Water
- Department of Water and Sanitation
- Department of Agriculture
- Traffic and Security reporting to the Fire and Emergency Services control room.
- Fire and Emergency Services

3. Response Protocol

- Whoever receives the call notifying them of a spill must report it to the Fire and Emergency services control room for recording purposes. (033 8455911/0800033911)
- The Fire and Emergency services control room then reports the incident to the Chief Fire Officer, Msunduzi Municipality Department of Environmental Health , Disaster Management Manager , Chief Traffic and Security
- The Msunduzi Municipality Department of Environmental Health responds to the incident as per the attached schedule

⁶³ Draft document. In the process of being finalised by Mike Greatwood (from Msunduzi Municipality, Water Services Authority)

POLLUTION INCIDENT RESPONSE PROTOCOL BY MSUNDUZI MUNICIPALITY DEPT OF ENVIRONMENTAL HEALTH

<p><u>Land or River based spill and fire and emergency services are first responder</u></p>	<p>Emergency incident resulting in a spill to which the Fire and Emergency Services responded to as a result of a call out.</p>	<ul style="list-style-type: none"> • In the event that the Fire and Emergency Services are the first responders the Msunduzi Municipality Department of Environmental Health upon receipt of information will act in support of the Fire and Emergency Services until the Fire and Emergency Services deem the situation to be safe and then the Msunduzi Municipality Department of Environmental Health will take over the incident in terms of this protocol
<p><u>Land Based spill</u></p>	<p>No potential river pollution</p>	<ul style="list-style-type: none"> • The Msunduzi Municipality Department of Environmental Health informs <ul style="list-style-type: none"> ○ Umgeni Water, ○ Department of Water and Sanitation, ○ Department of Agriculture (<i>for information purposes.</i>) ○ Department of Economic Development, Tourism and Environmental Affairs • Determine type of pollutant • Hold an immediate on site meeting of all relevant role players to determine clean-up action and further action • Determine need for <ul style="list-style-type: none"> ○ internal clean-up procedures ○ for appointment of clean-up company • Get Approval from the Municipal Manger (MM) • Report decision to Fire and Emergency Services Control Room • Appoint clean up company • Continuous monitoring of situation. • Close out report to:- <ul style="list-style-type: none"> ○ MANCO ○ Manager Fire and Emergency Services ○ Manager Water and Drainage ○ Disaster Management ○ Umgeni Water ○ Department of Water Affairs ○ Department of Agriculture ○ Department of Economic Development, Tourism and Environmental Affairs
<p><u>Land Based Spill</u></p>	<p>River pollution likely (urgent response required)</p>	<ul style="list-style-type: none"> • Report incident as a matter of urgency to:- <ul style="list-style-type: none"> ○ Msunduzi Municipality Chief Fire Officer ○ Msunduzi Municipality Manager Water and Drainage ○ Manager Traffic and Security ○ Umgeni Water ○ Dept. of Water and Sanitation ○ Dept. of Agriculture ○ Dept. of Economic Development, Tourism and Environmental Affairs • Determine type of pollutant • Hold an immediate on site meeting of all relevant role players to determine clean-up action and further action • Determine need for clean-up company • Get Approval from DMM • Report decision to Fire and Emergency Services Control Room • Appoint clean up company • Continuous monitoring of situation. • Close out report to:- <ul style="list-style-type: none"> ○ MANCO

		<ul style="list-style-type: none"> o Manager Fire and Emergency Services o Disaster Management o Umgeni Water o Department of Water and Sanitation o Department of Agriculture o Department of Economic Development, Tourism and Environmental Affairs
<u>Direct pollution into a river course</u>	River already polluted	<ul style="list-style-type: none"> • Report incident as a matter of urgency to:- <ul style="list-style-type: none"> o Msunduzi Municipality Manager Water and Drainage o Manager Traffic and Security o Umgeni Water o Dept. of Water and Sanitation o Dept. of Agriculture • Hold an immediate on site meeting of all relevant role players to determine clean-up action and further action • Determine type of pollutant • Determine extent and clean-up action • Determine need for clean-up company • Get Approval from MM • Report decision to Fire and Emergency Services Control Room • Appoint clean up company • Continuous monitoring of situation. • Close out and Rehabilitation Report to:- <ul style="list-style-type: none"> o MANCO o Manager Fire and Emergency Services o Disaster Management o Umgeni Water o Department of Water and Sanitation o Department of Agriculture o Department of Economic Development, Tourism and Environmental Affairs

Prepared 25/09/10

Unit	Responsible person	Unit/section	Contact Details
Fire and Emergency Services control room			
Environmental Health			
Chief Fire officer			
Chief Traffic and Security			
Manager Water and Drainage			
Disaster Management Manager			
Umgeni Water			
National Department of Water and Sanitation	Nonkululeko Mokoena	Water Quality Management	Cell: 083 297 0832 Tell: 031 336 2789
	Nompumelelo Mdlalose	Water Quality Management	Cell: 082 808 9920 Tell: 031 336 2889
Department of Agriculture			
Msunduzi Municipality			
Umgeni Local Municipality			
Umgungundlovu District Municipality			

Appendix 15: Confirmation of Acceptance of the EMPr by the Applicant / Developer

I _____ land owner / applicant of _____ (property address) hereby accept the conditions and specifications in terms of the Msunduzi Municipalities Environmental Management Program, and will ensure that all staff / workers / contractors / sub-contractors / engineers and all other person/s involved in the development / building / project are made aware of the Environmental Management Program and the importance of ensuring compliance with the said document.

All staff / workers / contractors / sub-contractors / engineers and all other person/s involved in the development / building / project will receive environmental awareness training⁶⁴ which will be conducted by the site foremen or other relevant person/s. All staff will be requested to sign a register confirmed their attendance.

----- Name Of Land Owner	----- Contact Number	----- Signature Of Land Owner	----- Date
-----------------------------	-------------------------	----------------------------------	---------------

----- Name Of Engineer	----- Contact Number	----- Signature Of Engineer	----- Date
---------------------------	-------------------------	--------------------------------	---------------

----- Name Of Contractor	----- Contact Number	----- Signature Of Contractor	----- Date
-----------------------------	-------------------------	----------------------------------	---------------

⁶⁴ In terms of Appendix 13 of the Msunduzi EMPr

Date: August 2016

Report Prepared By: Ms Kerina Singh and Mr Gideon Duma

Report Approved By: Mr Rodney Bartholomew

Msunduzi Municipality
Environmental Management Unit
P O Box 31
Pietermaritzburg
3200

Physical address:
411 Boom Street
Pietermaritzburg
3200

Tel: 033 392 3244

Email: Kerina.Singh@msunduzi.gov.za
Gideon.Duma@msunduzi.gov.za
Rodney.Bartholomew@msunduzi.gov.za

Website: www.msunduzi.gov.za

